

INFORMATION BOOKLET

RIVER PARK VILLAGE CONDOMINIUM

A 38 Unit Residential Condominium

Northville, Michigan

Developed By

RIVER PARK VILLAGE BUILDING CO., L.L.C.
32000 Northwestern Highway
Suite 220
Farmington Hills, Michigan 48334
(248) 851-9900

Effective Date: March 7, 2001

INFORMATION BOOKLET

RIVER PARK VILLAGE CONDOMINIUM

Table of Contents

- I. Disclosure Statement
Appendix A to Disclosure Statement – 2001 Estimated Budget
Builder's Supplement to Disclosure Statement

- II. Master Deed
 - Bylaws as Exhibit A
 - Condominium Subdivision Plan as Exhibit B

- III. Articles of Incorporation

- IV. Escrow Agreement

I. DISCLOSURE STATEMENT

DISCLOSURE STATEMENT

River Park Village Condominium
Northville, Michigan

Developed By:

River Park Village Building Co., L.L.C.
32000 Northwestern Highway
Suite 220
Farmington Hills, Michigan 48334
(248) 851-9900

Effective Date: March 7, 2001

River Park Village is a residential condominium project comprised of 38 condominium units.

THIS DISCLOSURE STATEMENT IS NOT A SUBSTITUTE FOR THE MASTER DEED OR OTHER APPLICABLE LEGAL DOCUMENTS. PURCHASERS SHOULD READ ALL SUCH DOCUMENTS FULLY TO ACQUAINT THEMSELVES WITH THE PROJECT AND THEIR RIGHTS AND RESPONSIBILITIES RELATING THERETO.

PRIOR TO PURCHASING A CONDOMINIUM UNIT, PURCHASERS SHOULD CONSULT THEIR OWN PROFESSIONAL ADVISORS.

DISCLOSURE STATEMENT

RIVER PARK VILLAGE CONDOMINIUM

I. Introduction.

Condominium development in Michigan is governed largely by the Michigan Condominium Act, being Act 59 of the Michigan Public Acts of 1978, as amended.

This Disclosure Statement, together with copies of the legal documents required for the creation and operation of the condominium, are furnished to each purchaser pursuant to the requirement of the Michigan Condominium Act that the Developer of a condominium disclose to prospective purchasers the characteristics of the condominium units which are offered for sale. This Disclosure Statement, along with the documents contained in the Purchaser Information Booklet, are the only authorized description of River Park Village. The Developer's officers, employees and agents (including but not limited to sales representatives) are not permitted to vary the terms contained therein.

II. The Condominium Concept.

A condominium is a method of subdividing and describing real property. A condominium unit has the same legal attributes as any other form of real property under Michigan law and may be sold, mortgaged or leased, subject only to such restrictions as are contained in the condominium documents or as otherwise may be applicable to the property.

Each co-owner receives a deed to the individual condominium unit purchased. Each co-owner owns, in addition to the unit purchased, as undivided interest in the condominium's common facilities ("common elements"). Title to the common elements is included as part of, and is inseparable from, title to the individual condominium units. Each owner's proportionate share of the common elements is determined by the percentage of value assigned to the owner's unit in the Master Deed. The Master Deed, which is described in Section IV of this Disclosure Statement, must be examined carefully to determine each co-owner's rights and obligations with respect to common elements.

All portions of the condominium not included within the units constitute the common elements. Limited common elements are those common elements set aside for use by less than all unit owners. General common elements are all common elements other than limited common elements.

The proximity of the units in the condominium and each co-owner's right, in common with all other co-owners, to use the general common elements, dictates that certain restrictions and obligations be imposed on each co-owner for the mutual benefit of all co-owners. The restrictions and obligations are set forth in the Master Deed and in the Bylaws which are attached

as Exhibit A to the Master Deed. All owners and unit occupants must be familiar with and abide by such restrictions and obligations.

The management and administration of the condominium is the responsibility of the River Park Village Condominium Homeowners' Association, a Michigan nonprofit corporation, of which all co-owners are members ("Association"). The nature and duties of the Association are set forth in the Condominium Bylaws attached as Exhibit A to the Master Deed and are summarized in Section VI of this Disclosure Statement.

Except for the year in which a unit is first established as part of the condominium, real property taxes and assessments are levied individually against each unit in the condominium. The separate taxes and assessments cover the unit and its proportionate share of the common elements. No taxes are levied independently against the common elements.

The foregoing is necessarily generalized to some degree. Accordingly, each purchaser is urged to review carefully all of the documents contained in the Purchaser Information Booklet for the condominium as well as any other documents that have been delivered to the purchaser in connection with this development. Any purchaser having questions pertaining to the legal aspects of the condominium is advised to consult the purchaser's own lawyer or other professional advisor.

III. Description of the Condominium.

A. Size, Scope and Physical Characteristics of the Condominium. The condominium has been established as a 38 unit residential condominium, in 3 buildings, located in Northville, Michigan. The Master Deed describes certain limited common elements which are reserved for the use of specific co-owners, such as porches and decks. Parking for each unit is provided by a garage attached to each unit.

B. Improvements Labeled "Must be Built" or "Need Not be Built". The Condominium Act requires that proposed structures and improvements be labeled in the Condominium Subdivision Plan as either "must be built" or "need not be built." The Condominium Plan does not identify any of the structures or improvements indicated thereon as "must be built," all of the same being deemed "need not be built" improvements. The Developer has arranged financing for the construction of the improvements within the Condominium through its own equity and a construction loan from Comerica Bank.

C. Recreational Facilities. There are no recreational areas or facilities in the condominium.

D. Private Roads. The roads and drives in the condominium are private. The roads and drives in the condominium will be maintained (including, without limitation, snow removal) by the Association, not Northville or any other governmental agency. Replacement, repair and resurfacing will be necessary from time to time as circumstances dictate. It is impossible to estimate with any degree of accuracy future road repair or replacement costs. It is the

Association's responsibility to inspect and to perform preventive maintenance of condominium roads and drives on a regular basis in order to maximize the life of such roads and drives and to minimize repair and replacement costs.

E. Utilities. The condominium is served by public water and sanitary sewers, as well as natural gas, electric, cable television and telephone service. All utilities, with the exception of water and sanitary sewer service, will be separately metered for payment by the individual unit owners. Water and sanitary sewer service fees and charges will be paid by the unit owners as a portion of their assessments due to the River Park Village Condominium Homeowners Association. Such fees and charges will be based on the percentage of value applicable to each unit in the condominium.

F. Reserved Rights of Developer.

(1) Modification of the Condominium. Developer has reserved the right, to modify the size, location and configuration of any Unit that it owns in the condominium, and to make corresponding changes to the Common Elements. Any such modification (or modifications) shall occur, if at all, within six years of the date of recording the Master Deed.

(2) Convertible Areas. In order to facilitate the development and sale of the condominium, Developer has reserved the right, at any time on or before six years after recordation of the original Master Deed, to modify, expand, move or delete units and to add to or modify limited and/or general common elements within the convertible areas described in the Master Deed and identified as such on the Condominium Subdivision Plan.

(3) Improvements and Landscape. Until a majority of the Board of Directors of the River Park Village Condominium Homeowners' Association are elected by Co-owners unaffiliated with Developer, no exterior modifications of any type may be made to any Unit without Developer's approval.

(4) Conduct of Commercial Activities. Until a majority of the Board of Directors of the River Park Village Condominium Homeowners' Association are elected by Co-owners unaffiliated with Developer, Developer has reserved the right to maintain on the condominium premises a sales office, advertising display signs, a business office, storage areas, reasonable parking incident to the use of such areas, and such access to, from and over the condominium premises as may be reasonable to enable development and sale of the entire condominium. Developer has reserved the right, for itself and its affiliates, to use two of the units in the condominium as model units in connection with its (and their) marketing and sales efforts with respect to the condominium and other development projects.

(5) Right to Amend. Developer has reserved the right to amend the Master Deed and the exhibits thereto without approval from co-owners and mortgagees for certain purposes specified in the Master Deed. Those purposes include, but are not limited to, converting the convertible areas, correcting errors and for any other purpose so long as the amendment would not materially alter or change the rights of a co-owner or mortgagee. Further,

certain provisions of the Master Deed cannot be amended without Developer approval.

(6) Easements, Restrictions and Agreements.

(a) For Use of Utilities. Developer has reserved easements to utilize, tap, tie into, extend and enlarge all utility mains in the condominium in connection with the exercise of its rights with respect to the development of any land adjacent to the condominium now or hereafter owned by Developer and/or its affiliates.

(b) For Use of Roads. Developer has reserved easements and rights of use over any roads and walkways in the condominium for the purpose of ingress and egress to or from all or any portion of any land adjacent to the condominium now or hereafter owned by the Developer and/or its affiliates, regardless of how such land ultimately may be used. If any dwelling unit using the roads in the condominium is not a unit in the condominium, then such unit shall pay a pro rata share of the expense of maintenance, repair, or replacement of the portion of the road which is used, which share shall be determined pro rata according to the total number of dwelling units using such portion of the road.

(c) Easement for Fire Suppression Equipment. Easements have been reserved over Units 1,13 and 27 of the Condominium and any other Unit which may, from time to time, contain fire suppression equipment servicing all or a portion of the building within which any such Unit may be located, such easements to be for the installation, operation, testing, maintenance, repair and replacement of fire suppression equipment located within such Units, which equipment services the buildings within which such Units are located.

(7) General. In the condominium documents and in the Michigan Condominium Act, certain rights and powers are granted or reserved to the Developer to facilitate the development and sale of the condominium, including the power to approve or disapprove a variety of proposed acts and uses and the power to secure representation on the Association Board of Directors.

IV. Legal Documentation.

A. General. The condominium was established pursuant to the Master Deed recorded in the Oakland County Records, and contained in the Purchaser Information Booklet for the condominium. The Master Deed includes the Bylaws as Exhibit A and the Condominium Subdivision Plan as Exhibit B.

B. Master Deed. The Master Deed contains the definitions of certain terms used in connection with the condominium, the percentage of value assigned to each unit in the condominium, a general description of the units and common elements included in the condominium and a statement regarding the relative responsibilities for maintaining the common elements. Article VIII of the Master Deed covers easements, Article X reserves in favor of Developer the right to amend the condominium documents for various purposes including, but not limited to, expanding the condominium, making changes therein, providing for the correction

of errors and complying with the requirements of certain lending institutions. Article IX sets forth Developer's right to the convert certain areas of the condominium.

C. Bylaws. The Bylaws contain provisions relating to the operation, management and fiscal affairs of the condominium and, in particular, set forth the provisions relating to the assessment of Association members for the purpose of paying the costs of operation of the condominium. Article VI of the Bylaws contains certain restrictions upon the ownership, occupancy and use of the condominium. Article VI also contains provisions permitting the adoption of rules and regulations governing the common elements.

D. Condominium Subdivision Plan. The Condominium Subdivision Plan is a three-dimensional survey depicting the physical location and boundaries of each of the units and all of the common elements in the condominium.

V. Experience of Certain Companies.

A. Developer's Background and Experience. The Developer, River Park Village Building Co., L.L.C., a Michigan limited liability company, is licensed as a residential builder, was formed for the specific purpose of developing the condominium, and has not previously developed any property. The members of Developer have substantial real estate development experience, having developed, through affiliates, over 1,000 residential housing sites and units since 1987. There are no pending judicial or administrative proceedings involving the condominium or Developer.

B. Management Agent. At present, the Developer has been engaged to act as management agent for the condominium.

VI. Operation of the Condominium.

A. The Condominium Association. The responsibility for management and maintenance of the condominium is vested in the Association. As each individual purchaser acquires title to a condominium unit, the purchaser will also become a member of the Association. The Articles of Incorporation of the Association are in the Purchaser Information Booklet, and along with the Bylaws, control procedural operations of the Association. The Association is governed by its Board of Directors whose initial members are designees of the Developer. Until a successor Board of Directors is elected by the members, the Association will be controlled by the Directors named by Developer. Developer's rights of representation on the Association's Board of Directors are set forth in Article XI of the Bylaws.

B. Percentages of Value. The percentage of value of each unit in the condominium is equal. The percentage of value assigned to each unit determines, among other things, the value of each co-owner's vote and the co-owner's proportionate share of regular and special Association assessments and of the proceeds of administration of the condominium.

C. Project Finances.

(1) Budget. Article II of the Bylaws requires the Board of Directors to adopt an annual budget for the operation of the condominium. The Association's only source of revenue to fund its budget is by the assessment of its members. The initial budget for the condominium was formulated by Developer and is intended to provide for the normal and reasonably predictable expenses of administration of the condominium, if developed with 94 units, and includes a reserve for replacement of major structural and other components of the condominium. To the extent that estimates prove inaccurate during actual operations and to the extent that the goods and services necessary to service the condominium change in cost in the future, the budget and the expenses of the Association also will require revision. The initial budget of the Association has been included as Appendix A to this Disclosure Statement. Developer makes no representation or warranty that the budget attached as Appendix A accurately reflects the assessments that will be charged by the Association.

(2) Assessments. Except as set forth below with respect to Developer, each co-owner of a unit included in the condominium must pay for the expenses of general administration of the Association in proportion to the percentage of value assigned to the unit(s) the co-owner owns. The Board of Directors may also levy special assessments in accordance with the provisions of Article II, Section 3(b) of the Bylaws. As set forth in Article II, Section 9 of the Bylaws, Developer does not pay Association assessments for the units it owns until they are occupied but does reimburse the Association for certain expenses it may incur for such units. In addition, Article VI, Section 16 of the Bylaws provides that the violation of any provisions of the Bylaws and/or the Master Deed, including any of the rules and regulations promulgated by the Board of Directors of the Association, by any co-owner (other than Developer), or tenant or occupant of such co-owner's Unit, shall be grounds for assessment by the Association of a monetary fine for such violation against such co-owner.

(3) Foreclosure of Lien. The Association has a lien on each unit to secure payment of Association assessments. The Bylaws provide that the Association may foreclose its lien in the same fashion that mortgages may be foreclosed by action or by advertisement under Michigan law.

(4) Possible Additional Liability. It is possible for co-owners to become obligated to pay a percentage share of assessment delinquencies incurred by other co-owners. This can happen if a delinquent co-owner defaults on a first mortgage and if the mortgagee forecloses. The delinquent assessments then become a common expense which is reallocated to all the co-owners, including the first mortgagee, in accordance with the percentages of value in the Master Deed. The Michigan Condominium Act (Section 58) provides:

If the mortgagee of a first mortgage of record or other purchaser of a condominium unit obtains title to the condominium unit as a result of foreclosure of the first mortgage, such person, its successors and assigns, is not liable for the assessments by the [Association] chargeable to the unit which became due prior to the acquisition of title to the unit by such

person. The unpaid assessments are deemed to be common expenses collectible from all of the condominium unit owners including such persons, its successors and assigns.

D. Insurance.

(1) Title Insurance. The Construction and Sales Agreement provides that Developer shall furnish each purchaser a commitment for an owner's title insurance policy at or prior to closing, and that the policy itself shall be ordered at closing. The cost of the owner's commitment and policy will be paid by the Developer.

(2) Other Insurance. The condominium documents require that the Association carry fire and extended coverage, vandalism and malicious mischief and liability insurance and workers' compensation insurance, if applicable, pertinent to the ownership, use and maintenance of the common elements of the condominium. The insurance policies have deductible clauses and, to the extent thereof, losses will be borne by the Association. The Board of Directors is responsible for obtaining insurance coverage for the Association. Each co-owner's pro rata share of the annual Association insurance premiums is included in the monthly assessment. The Association insurance policies are available for inspection during normal working hours. A copy of the Certificate of Insurance with respect to the condominium will be furnished to each co-owner upon request. The insurance coverage carried by the Association will not cover the interior of any individual unit, improvements installed by co-owners or any personal property of any co-owner.

Each co-owner is responsible for obtaining coverage with respect to the co-owner's unit and to the extent indicated in Article IV of the Bylaws. The Association should periodically review all insurance coverage to be assured of its continued adequacy and each co-owner should do the same with respect to the co-owner's personal insurance.

E. Restrictions on Ownership Occupancy and Use. Article VI of the Bylaws contains comprehensive restrictions on the use of the condominium units and the common elements. It is impossible to paraphrase these restrictions without risking the omission of some portion that may be of significance to a purchaser. Consequently, each purchaser should examine the restrictions with care to be sure that they do not infringe upon an important intended use. The following is a list of certain of the most significant restrictions:

(1) Units are to be used only for residential purposes.

(2) No animal, other than two cats or two dogs or one cat or one dog, each not to exceed 60 pounds in weight, shall be kept without the prior written consent of the Board of Directors. No savage or dangerous animals shall be kept. No loud or obnoxious birds shall be kept.

(3) There are substantial limitations upon physical changes which may be made to the units and common elements in the condominium and upon the uses to which the

common elements and units may be put.

(4) Reasonable regulations may be adopted by the Board of Directors of the Association concerning the use of common elements, without vote of the co-owners.

(5) Subject to the requirements set forth in Section 15 of Article VI, a co-owner (including Developer) may rent units owned by the co-owner at any time for any term of occupancy not less than one year. A co-owner must disclose the co-owner's intention to lease a unit and provide a copy of the exact lease form to the Association at least 10 days before presenting a lease to a potential lessee. Developer reserves the right to lease units and hereby notifies all Co-owners that it may do so if market conditions so require.

None of the restrictions apply to the commercial activities or signs of the Developer.

F. Association Litigation. The Articles of Incorporation of the Association and Article III of the Bylaws establish procedures that govern all Association litigation other than actions to enforce the Bylaws or collect delinquent assessments. As with the restrictions on ownership, occupancy and use, it is impossible to paraphrase these procedures without risking the omission of some portion that may be of significance to a purchaser.

VII. Rights and Obligations Between Developer and Co-owners.

A. Before Closing. The respective obligations of the Developer and the purchaser of a unit in the condominium prior to closing are set forth in the Construction and Sales Agreement and the accompanying Escrow Agreement. Those documents contain, among other provisions, the provisions relating to the disposition of earnest money deposits advanced by the purchaser prior to closing and the anticipated closing adjustments and should be closely examined by all purchasers. The Escrow Agreement provides that all deposits made under Construction and Sales Agreements be placed in escrow. The Escrow Agreement provides for the release of an escrow deposit to any purchaser who withdraws from a Construction and Sales Agreement in accordance with the Construction and Sales Agreement. Such a withdrawal is permitted by each Construction and Sales Agreement if it takes place within nine business days after the purchaser has received all of the condominium documents or if the condominium documents are changed in a way that materially reduces the purchaser's rights. The Escrow Agreement also provides that a deposit will be released to Developer if the purchaser defaults in any obligation under the Construction and Sales Agreement after the Construction and Sales Agreement has become binding upon the purchaser. The Escrow Agreement provides, pursuant to Section 103b of the Michigan Condominium Act, that the escrow agent shall maintain sufficient funds or other security to complete improvements labeled as "must be built" on the Condominium Subdivision Plan until such improvements are substantially complete. All improvements depicted on the Condominium Subdivision Plan have been labeled as "need not be built." Therefore, deposits will be released to the Developer when the purchaser's withdrawal right has lapsed. Each purchaser of a unit will receive a copy of the Escrow Agreement.

B. At Closing. Each purchaser will receive by warranty deed fee simple title to the

purchaser's unit subject to the condominium documents and easements and restrictions of record and the lien of taxes and assessments not yet due and payable.

C. After Closing.

(1) General. Subsequent to the purchase of the unit, the legal relationship between the Developer and the co-owner are governed by the Master Deed, except to the extent that any provisions of the Construction and Sales Agreement are intended to survive the closing.

(2) Warranty. Express warranties are not provided unless specifically stated in the Construction and Sales Agreement. A copy of the Developer's limited one-year warranty is provided to each purchaser along with and as a part of the Construction and Sales Agreement. The warranty excludes nailpops, plaster or concrete cracks or any other defect or problem arising from normal settlement or shifting or normal expansion or contraction of materials. Prior to closing the purchaser must carefully inspect the unit. In the event any defects in material or workmanship exist which are covered by the warranty, a written list of such defects must be made and presented to Developer prior to closing. Developer shall not be required to correct such defects prior to closing but shall do so as promptly as possible after the closing at Developer's own expense. After the closing, Developer's obligation to correct defects in the unit shall be strictly limited to those defects which are covered by the warranty. The warranty on purchaser's unit shall extend for a period of one year after closing. Written notice of any defect in the unit or in the common elements must be given to Developer within the applicable one-year period in order to be covered by the warranty. Developer's obligations under the warranty are limited to repair and replacement. As to items not of Developer's manufacture, such as any air conditioner, water heater, refrigerator, range, dishwasher or other appliances, Developer will assign to purchaser the manufacturer's warranty, without recourse. Developer makes no warranty on such items. DEVELOPER'S LIMITED ONE-YEAR WARRANTY IS THE ONLY WARRANTY APPLICABLE. ALL OTHER WARRANTIES, EXPRESS OR IMPLIED, WHETHER ARISING UNDER STATE LAW OR THE MAGNUSON-MOSS WARRANTY ACT, INCLUDING BUT NOT LIMITED TO ALL IMPLIED WARRANTIES OF FITNESS, MERCHANTABILITY OR HABITABILITY, ARE DISCLAIMED AND EXCLUDED.

(3) Limitation of Developer's Liability. The Construction and Sales Agreement strictly limits Developer's liability to the obligations provided in Developer's limited one-year warranty.

VIII. Purpose of Disclosure Statement.

This Disclosure Statement paraphrases various provisions of the Construction and Sales Agreement, Escrow Agreement, Master Deed and other documents required by law. It is not a complete statement of all the provisions of those documents which may be important to purchasers. In an attempt to be more readable, this Disclosure Statement omits most legal phrases, definitions and detailed provisions of the other documents. Certain of the terms used herein are defined in the Michigan Condominium Act, as amended. This Disclosure Statement is not a substitute for the legal documents which it draws information from and the rights of

purchasers and other parties will be controlled by the other legal documents and not by this Disclosure Statement.

The Michigan Department of Commerce publishes The Condominium Buyers Handbook which the Developer has delivered to you. The Developer assumes no obligation, liability, or responsibility as to the statements contained therein or omitted from The Condominium Buyers Handbook.

APPENDIX A
TO
RIVER PARK VILLAGE CONDOMINIUM
DISCLOSURE STATEMENT

2001 ESTIMATED ANNUAL BUDGET AND MONTHLY
ASSESSMENTS
(BASED ON 38 UNITS)

INCOME		
Association Fees	\$	55,434.00
TOTAL INCOME	\$	55,434.00
<i>Total Units</i>		38
<i>Average Monthly Fee Per Unit</i>	\$	122
EXPENSE		
Administrative		
Office Supplies/Printing	\$	800.00
Management Fee	\$	6,384.00
Audit/Legal	\$	1,000.00
Total Administrative	\$	8,184.00
Operations		
Electricity	\$	5,000.00
Exterminator	\$	500.00
Water & Sewer	\$	7,600.00
Total Operations	\$	13,100.00
Maintenance & Repair		
Building Maintenance	\$	2,500.00
Fire Suppression	\$	1,520.00
Lawn Maintenance	\$	2,500.00
Fertilizing	\$	400.00
Sprinkler System	\$	1,000.00
Landscaping	\$	3,500.00
Snow Removal	\$	5,700.00
Salt & Calcium Chloride	\$	3,705.00
Total Maintenance & Repair	\$	20,825.00
Tax, Fees & Insurance		
Corporate Tax & Permits	\$	25.00
Insurance	\$	7,600.00
Total Corp. Tax & Ins.	\$	7,625.00
Reserve Expenditures		
Transfer to Reserve Acct	\$	5,700.00
Total Reserve Expenses	\$	5,700.00
TOTAL OPERATING EXPENSES	\$	55,434.00

RIVER PARK VILLAGE CONDOMINIUM

BUILDER'S SUPPLEMENT TO DISCLOSURE STATEMENT

I. Builder's Background and Experience.

Builder, River Park Village Building Co., L.L.C., 32000 Northwestern Highway, Suite 220, Farmington Hills, Michigan 48334, is a licensed residential builder. River Park Village Building Co., L.L.C., itself, has no home building experience and was created solely to develop the River Park Village Condominium and to build homes within the Condominium. The members of River Park Village Building Co., L.L.C., though, through affiliates, have substantial home building experience, including home building in the Harbour Pointe on the Lake Condominium in Waterford Township, Michigan, the Pinebrook, Pinecreek and Arbor Oaks Subdivisions as well as the Pine Meadow Condominium located in Farmington Hills, Michigan, the Springbrook Meadows Condominium located in Commerce Township, Michigan, the Woods of Canton and Pine Cove Subdivisions located in Livonia, Michigan and the West Village Condominium located in Dearborn, Michigan among others.

II. Rights and Obligations Between Builder and Owners.

A. **Before Closing.** The respective obligations of the Builder and the purchaser of a unit in River Park Village Condominium prior to closing are set forth in the Construction and Sales Agreement (referred to below as the Purchase Agreement) and the accompanying Escrow Agreement. Those documents contain, among other provisions, the provisions relating to the disposition of earnest money deposits advanced by the purchaser prior to closing and the anticipated closing adjustments, and should be closely examined by all purchasers. The Escrow Agreement provides that all deposits made under Purchase Agreements be placed in escrow. The Escrow Agreement provides for the release of an escrow deposit to any purchaser who withdraws from a Purchase Agreement in accordance with the Purchase Agreement. Such a withdrawal is permitted by each Purchase Agreement if it takes place within nine business days after the purchaser has received all of the condominium documents or if the condominium documents are changed in a way that materially reduces the purchaser's rights. The Escrow Agreement also provides that a deposit will be released to the Builder if the purchaser defaults in any obligation under the Purchase Agreement after the Purchase Agreement has become binding upon the purchaser. The Escrow Agreement provides, pursuant to Section 103b of the Michigan Condominium Act, that the escrow agent shall maintain sufficient funds or other security to complete improvements labeled as "must be built" on the Condominium Subdivision Plan until such improvements are substantially complete. All improvements depicted on the Condominium Subdivision Plan have been labeled as "need not be built." The Escrow Agreement, provides, therefore, that the deposits will be released to Builder when the purchaser's withdrawal right has lapsed. Each purchaser of a unit will receive a copy of the Escrow Agreement.

B. **At Closing.** Each purchaser will receive by warranty deed fee simple title to the purchaser's unit subject to the condominium documents and easements and restrictions of record and the lien of taxes and assessments (including installments of assessments) not yet due and payable. The Purchase Agreement provides that the Builder will give each purchaser a commitment for an owner's title insurance policy at or prior to closing, and that the policy itself shall be ordered at closing. The cost of the owner's commitment and policy is to be borne by the Builder.

C. **After Closing.**

(1) **General.** Subsequent to the purchase of the unit, the legal relationship between the Builder and the Purchaser are governed by the Master Deed, except to the extent that any provisions of the Purchase Agreement are intended to survive the closing.

(2) **Limited Warranty.** Express warranties are not provided unless specifically stated in the Purchase Agreement. The only warranty provided by Builder is the limited warranty provided to purchaser with the Purchase Agreement. Among other things, the limited warranty does not apply to defects or damages which are the result of normal expansion or contraction or the result of other normal characteristics of building materials. Prior to closing the purchaser must carefully inspect the home built by Builder on the unit. In the event any defects in material or workmanship exist which are covered by the limited warranty, a written list of such defects must be made and presented to Builder prior to closing. Builder shall not be required to correct defects which are covered by the limited warranty prior to closing but shall do so as promptly as possible after the closing at Builder's own expense. After the closing, Builder's obligation to correct defects in the home shall be strictly limited to those defects which are covered by the limited warranty and were listed by the purchaser in writing prior to the closing and those defects which are covered by the limited warranty and which are latent and could not have been discovered by the purchaser prior to closing. The limited warranty on purchaser's home shall extend for a period of one year after closing. The Builder's limited warranty applies only to the home purchased, not to any common elements of River Park Village Condominium such as roads, detention basins or utilities. Written notice of any defect in the home or in the common elements must be given to Builder within the applicable one-year period and in accordance with Builder's New Home Limited Warranty Guidelines in order to be covered by the limited warranty. Builder's obligations under the warranty are expressly limited to repair and replacement and Builder shall not be responsible for any consequential or other damages. As to items not of Builder's manufacture, such as any air conditioner, water heater, refrigerator, range, dishwasher or other appliances, Builder will assign to purchaser the manufacturer's warranty, without recourse. Builder makes no warranty on such items. THE LIMITED WARRANTY DESCRIBED HEREIN IS THE ONLY WARRANTY APPLICABLE. ALL OTHER WARRANTIES, EXPRESS OR IMPLIED, WHETHER ARISING UNDER STATE LAW OR THE MAGNUSON-MOSS WARRANTY ACT, INCLUDING, BUT NOT LIMITED TO, ALL IMPLIED WARRANTIES OF FITNESS, MERCHANTABILITY OR HABITABILITY, ARE DISCLAIMED AND EXCLUDED.

(3) **Limitation of Builder's Liability.** The Purchase Agreement strictly limits Builder's liability whether in contract, tort, under any warranty, in negligence or otherwise, to the obligations provided in Builder's limited warranty. Builder is not liable to purchaser for or responsible to compensate or indemnify purchaser for any damage, claim, demand, loss, cost or expense resulting from an alleged claim of breach of warranty, whether relating to injury to persons, property, or otherwise, or relating to the presence of any toxic or hazardous waste, substance or contaminant, including without limitation radon gas, in, on, or under the purchaser's unit and home, River Park Village Condominium development, or the real estate adjacent to or in close proximity with River Park Village Condominium development. The Purchase Agreement further provides that Builder shall in no circumstances be liable for any consequential, incidental, special or secondary damages even if Builder has been advised of the possibility of such damages. All of purchaser's rights relating to the Purchase Agreement, the limited warranty, the unit and appurtenant common elements may be asserted only by purchaser and not by any association or class representative. Builder makes no representations or warranties (other than the limited warranty described above) in the Purchase Agreement or otherwise concerning the unit, River Park Village Condominium, the value or resale value of the unit, the real estate adjacent to or in close proximity with River Park Village Condominium or the condition of the air, the soils, surface waters, and groundwaters in, on or under the unit, River Park Village Condominium or such adjacent or proximate real estate. Purchaser should make its own investigation prior to executing the Purchase Agreement with respect to each of the foregoing. Without purchaser's agreement to and acknowledgement of the provisions of the Purchase Agreement and limited warranty described above, Builder would not agree to sell the purchaser's unit to purchaser.

III. Radon Gas.

Radon is a naturally-occurring, colorless and odorless radioactive gas formed by the breakdown of uranium and radium deposits in the soil. Radon can escape from the soil and enter buildings. Preliminary studies by the United States Environmental Protection Agency (EPA) suggest that prolonged exposure to radon may result in adverse health consequences.

The extent to which an area or unit may be exposed to radon depends upon a number of factors, including natural geologic conditions, prior land use, groundwater, construction materials and techniques, ventilation and air-conditioning systems, and homeowner maintenance. Because of the multitude of factors involved, it is difficult to predict whether a specific residence may be subject to high radon levels unless specific tests are conducted by experts in the area.

Builder neither has nor claims any expertise in radon, and it does not provide advice to homeowners about the acceptable levels or possible health hazards of radon. It is possible that tests or studies might disclose information which a purchaser might consider significant in deciding whether to purchase a unit in River Park Village Condominium from Builder. Builder assumes no responsibility to make any tests or studies.

The EPA, as well as state and local regulatory authorities, are best equipped to render advice regarding the risks which may exist in a particular area, the risks associated with radon

exposure, the methods available to detect and measure radon levels, and whether remedial measures may be advisable in particular circumstances to reduce the risk of radon exposure. The EPA has published two guides which are available to interested persons: "A Citizen's Guide to Radon: What It Is and What To Do About It" and "Radon Reduction Methods: A Homeowner's Guide."

IV. Purpose of Builder's Supplement to Disclosure Statement.

This Builder's Supplement to Disclosure Statement paraphrases various provisions of the Purchase Agreement, Escrow Agreement, New Home Limited Warranty and other documents required by law. It is not a complete statement of all the provisions of those documents which may be important to purchasers. In an attempt to be more readable, this Builder's Supplement omits most legal phrases, definitions and detailed provisions of the other documents. Certain of the terms used herein are defined in the Michigan Condominium Act, as amended. This Builder's Supplement is not a substitute for the legal documents which it draws information from, and the rights of purchasers and other parties will be controlled by the other legal documents and not by this Builder's Supplement to Disclosure Statement.

Builder has prepared this Builder's Supplement to Disclosure Statement in good faith, in reliance upon sources of information believed to be accurate and in an effort to disclose material facts about this transaction. Builder disclaims liability to any purchaser for misstatements in the Builder's Supplement to Disclosure Statement (or for omissions which make statements herein appear misleading) if such misstatements were made by Builder in good faith, or were immaterial in nature, or were not relied upon by the purchaser, or did not result in any damages to the purchaser.

Each purchaser is urged to engage a competent lawyer or other advisor in connection with the purchaser's decision to purchase a unit. In accepting title to a unit in River Park Village Condominium, each purchaser shall be deemed to have waived any claim or right arising out of or relating to any immaterial defect, omission or misstatement in this Builder's Supplement to Disclosure Statement. In preparing this Builder's Supplement to Disclosure Statement, and the other condominium documents, Builder's counsel has not undertaken professional responsibility to the association or to any owners or mortgagees for the completeness, accuracy, or validity of the condominium documents.

The Michigan Department of Commerce publishes The Condominium Buyer's Handbook which the Builder has delivered to you. The Builder assumes no obligation, liability, or responsibility as to the statements contained therein or omitted from The Condominium Buyer's Handbook.

II. MASTER DEED

OAKLAND COUNTY, MISSOURI, hereby certifies that there is no tax liability by the state or any individual against the state and all TAXES on same are paid for the year of date of this instrument as appears by the records of the county except as stated.

LIBER 22409 PG 001

COPY

51922

FEB 20 2001

LIBER 22409 PAGE 1
\$95.00 DEED - COMBINED
\$2.00 REMUNERATION
03/02/2001 08:33:38 A.M. RECEIPT# 12825
PAID RECORDED - OAKLAND COUNTY
G. WILLIAM CABELL, CLERK/REGISTER OF DEEDS

7.60 Lm C. HUGH COHANY, County Treasurer
Sec. 135, Act 208, 1893 as amended

003877

RIVER PARK VILLAGE CONDOMINIUM

MASTER DEED

THIS MASTER DEED ("Master Deed") is made this December 16, 2000, by RIVER PARK VILLAGE BUILDING CO., L.L.C., a Michigan limited liability company ("Developer"), whose address is 32000 Northwestern Highway, Suite 220, Farmington Hills, Michigan 48334.

RECITALS:

A. Developer desires by recording this Master Deed, together with the Bylaws (defined below) attached hereto as Exhibit A and the Condominium Subdivision Plan (defined below) attached hereto as Exhibit B (both of which are hereby incorporated herein by reference and made a part hereof), to establish the real property described in Article II below, together with the improvements located and to be located thereon, and the appurtenances thereto, as a residential condominium project under the provisions of the Act (defined below).

NOW, THEREFORE, Developer, upon the recording hereof, establishes RIVER PARK VILLAGE CONDOMINIUM as a condominium project under the Act and declares that RIVER PARK VILLAGE CONDOMINIUM shall be held, conveyed, hypothecated, encumbered, leased, rented, occupied, improved, or in any other manner utilized, subject to the provisions of the Act, and to the covenants, conditions, restrictions, uses, limitations and affirmative obligations set forth in this Master Deed, the Bylaws and the Condominium Subdivision Plan, all of which shall be deemed to run with the land and shall be a burden and a benefit to Developer, its successors, successors-in-interest and assigns and any persons acquiring or owning an interest in the Condominium Premises (defined below) and their respective grantees, successors, successors-in-interest, heirs, executors, administrators and assigns. In furtherance of the establishment of the Condominium (defined below), it is provided as follows:

45P
R

ARTICLE I

TITLE AND NATURE

The Condominium shall be known as RIVER PARK VILLAGE CONDOMINIUM, Oakland County Condominium Subdivision Plan No. 1332. The engineering and architectural plans for the Project (defined below) were approved by and are on file with the City of Northville. The Condominium is established in accordance with the Act. The buildings contained in the Condominium, including the number, boundaries, dimensions and area of each Unit (defined below) therein, are set forth completely in the Condominium Subdivision Plan. The buildings contain individual Units for residential purposes and each Unit is capable of individual utilization on account of having its own entrance from and exit to a Common Element (defined below) of the Condominium Project. Each Co-owner (defined below) in the Condominium Project shall have an exclusive right to his Unit and shall have undivided and inseparable rights to share with other Co-owners the Common Elements of the Condominium Project (defined below).

ARTICLE II

LEGAL DESCRIPTION

The land which is submitted to the Condominium Project established by this Master Deed is described as follows:

Part of the Southeast ¼ of Section 34, Town 1 North, Range 8 East, City of Northville (formerly Novi Township), Oakland County, Michigan, more particularly described as:

Beginning at the Southeast corner of said Section 34; thence West, along the South line of Section 34 and the center line of Base Line Road, 519.76 feet; thence North 15°53'37" East, along the Easterly line of the C&O Rail Road right-of-way (formerly the Pere Marquette Railroad), 222.77 feet (recorded as about 223 feet), to the Southeast corner of the Southeast concrete pier of a rail road bridge over the Middle Rouge River; thence East, parallel with the South line of Section 34, 458.24 feet; thence South 00°08'21" East, along the East line of Section 34 and the center line of Old Novi Road (66 feet wide), 214.25 feet to the Point of Beginning. Containing 2.405 acres of land, more or less, inclusive of road rights of way. Subject to the rights of the public over the South 33 feet for Base Line Road and the East 33 feet for Old Novi Road.

ARTICLE III

DEFINITIONS

Certain terms are utilized not only in this Master Deed and Exhibits A and B hereto, but are or may be used in various other instruments such as, by way of example and not limitation, the Articles of Incorporation and rules and regulations of the RIVER PARK VILLAGE CONDOMINIUM HOMEOWNERS' ASSOCIATION, a Michigan non-profit corporation, and deeds, mortgages, liens, land contracts, easements and other instruments affecting the establishment of, or transfer of, interests in RIVER PARK VILLAGE CONDOMINIUM as a condominium. Wherever used in such documents or any other pertinent instruments, the terms set forth below shall be defined as follows:

1. **Act.** The "Act" means the Michigan Condominium Act, being Act 59 of the Public Acts of 1978, as amended.
2. **Association.** "Association" means RIVER PARK VILLAGE CONDOMINIUM HOMEOWNERS' ASSOCIATION, which is the non-profit corporation organized under Michigan law, of which all Co-owners shall be members, which corporation shall administer, operate, manage and maintain the Condominium. Any action required of or permitted to be taken by the Association shall be exercisable by its Board of Directors unless specifically reserved to its members by the Condominium Documents or the laws of the State of Michigan.
3. **Bylaws.** "Bylaws" means Exhibit A hereto, being the Bylaws setting forth the substantive rights and obligations of the Co-owners and required by Section 3(8) of the Act to be recorded as part of the Master Deed. The Bylaws shall also constitute the corporate bylaws of the Association as provided for under the Michigan Nonprofit Corporation Act.
4. **Common Elements.** "Common Elements," where used without modification, means both the General and Limited Common Elements described in Article IV hereof.

5. **Condominium Documents.** "Condominium Documents" means and includes this Master Deed and Exhibits A and B and all other exhibits hereto, and the Articles of Incorporation and rules and regulations, if any, of the Association, as all of the same may be amended from time to time.

6. **Condominium Premises.** "Condominium Premises" means and includes the land described in Article II above, all improvements and structures thereon, and all easements, rights and appurtenances belonging to RIVER PARK VILLAGE CONDOMINIUM as described above.

7. **Condominium Project, Condominium or Project.** "Condominium Project", "Condominium" or "Project" each mean RIVER PARK VILLAGE CONDOMINIUM as a Condominium Project established in conformity with the Act.

8. **Condominium Subdivision Plan.** "Condominium Subdivision Plan" means Exhibit B hereto.

9. **Consolidating Master Deed.** "Consolidating Master Deed" means the final amended Master Deed which shall describe RIVER PARK VILLAGE CONDOMINIUM as a completed Condominium Project and shall reflect the entire land area added to the Condominium from time to time, and all Units and Common Elements therein, and which shall express percentages of value pertinent to each Unit as finally readjusted. Such Consolidating Master Deed, when recorded in the office of the Oakland County Register of Deeds, shall supersede the previously recorded Master Deed for the Condominium and all amendments thereto.

10. **Construction and Sales Period.** "Construction and Sales Period," for the purposes of the Condominium Documents and the rights reserved to the Developer thereunder, means the period commencing with the recording of the Master Deed and continuing as long as the Developer owns any Unit which it offers for sale or for so long as the Developer is entitled to add Units to the Project under this Master Deed.

11. **Co-owner or Owner.** "Co-owner" means a person, firm, corporation, partnership, limited liability company, association, trust or other legal entity or any combination thereof who or which owns one or more Units in the Condominium Project. The term "Owner," wherever used, shall be synonymous with the term "Co-owner". Developer is a Co-owner as long as Developer owns one or more Units.

12. **Developer.** "Developer" means River Park Village Building Co., L.L.C., a Michigan limited liability company, which has made and executed this Master Deed, and its successors and assigns. Both successors and assigns shall always be deemed to be included within the term "Developer" whenever, however and wherever such term is used in the Condominium Documents.

13. **First Annual Meeting.** "First Annual Meeting" means the initial meeting at which non-developer Co-owners are permitted to vote for the election of all Directors and upon all other matters which properly may be brought before the meeting. Such meeting is to be held (a) in the Developer's sole discretion after 50% of the Units are conveyed, or (b) mandatorily within (i) 54 months from the date of the first Unit conveyance, or (ii) 120 days after 75% of all Units are conveyed, whichever first occurs.

14. **Township.** "Township" means Northville Township, Michigan.

15. **Transitional Control Date.** "Transitional Control Date" means the date on which a Board of Directors of the Association takes office pursuant to an election in which the votes which may be cast by eligible Co-owners unaffiliated with the Developer exceed the votes which may be cast by the Developer.

16. **Unit or Condominium Unit.** "Unit" or "Condominium Unit" each mean the enclosed space constituting a single complete residential Unit in RIVER PARK VILLAGE CONDOMINIUM, as such space may be described in the Condominium Subdivision Plan, and shall have the same meaning as the term "Condominium Unit" as defined in the Act.

Whenever any reference herein is made to one gender, the same shall include a reference to any and all genders where the same would be appropriate; similarly, whenever a reference is made herein to the singular, a reference to the plural shall also be included where the same would be appropriate and vice versa.

ARTICLE IV
COMMON ELEMENTS

The Common Elements of the Project and the respective responsibilities for maintenance, decoration, repair or replacement thereof, are as follows:

I. **General Common Elements.** The General Common Elements are:

(a) Land. The land described in Article II hereof, including the roadways, general common element sidewalks, walking paths, the open space shown on the Condominium Subdivision Plan, the landscaping within the Condominium, retaining walls, screening walls, detention basins, General Common Element lighting and all other areas within the Condominium not otherwise identified herein as Limited Common Elements or as Units.

(b) Electrical. The electrical transmission system throughout the Project up to the electrical meter for each Unit.

(c) Telephone. The telephone system throughout the Project up to the point of entry to each Unit.

(d) Mailbox Structure. The mailbox structures and individual mailboxes (but not the right to use nor the interior space within any individual mailbox which right to use and interior space is expressly reserved to the Co-Owner of the Unit to which the same is appurtenant).

(e) Gas. The gas distribution system throughout the Project up to the gas meter for each Unit.

(f) Water. The water distribution system throughout the Project up to the meter for each Unit, including any fire suppression equipment, if any, located within the interior of any Unit or exterior to any Unit.

(g) Sanitary Sewer. The sanitary sewer system throughout the Project up to the point of connections for individual Unit service.

(h) Storm Sewer. The storm sewer system throughout the Project and otherwise appurtenant to the Project located upon premises adjacent to the Condominium Premises.

(i) Telecommunications. The telecommunications system throughout the Project, if and when it may be installed, up to, but not including, connections to provide service to individual Units.

(j) Construction. Foundations, supporting columns, Unit perimeter walls (but not including windows and doors therein), roofs, ceilings, floor construction between Unit levels and chimneys.

(k) Other. Such other elements of the Project not herein designated as General or Limited Common Elements which are not enclosed within the boundaries of a Unit, and which are intended for common use or are necessary to the existence, upkeep and safety of the Project.

Some or all of the utility lines, systems (including mains and service leads) and equipment and the water system described above may be owned by the local public authority or by the company that is providing the pertinent service. Accordingly, such utility lines, systems and equipment, and the water system, shall be General

Common Elements only to the extent of the Co-owners' interest therein, if any, and the Developer makes no warranty whatsoever with respect to the nature or extent of such interest, if any.

2. **Limited Common Elements.** Limited Common Elements shall be subject to the exclusive use and enjoyment of the Owner of the Unit to which the Limited Common Elements are appurtenant. The Limited Common Elements are:

(a) Porch. Each individual porch is restricted in use to the Co-owner of the Unit served thereby as shown on Exhibit B hereto.

(b) Deck. Each individual deck is restricted in use to the Co-owner of the Unit to which it adjoins.

(c) Patio. Each individual patio is restricted in use to the Co-owner of the Unit to which it adjoins.

(d) Unit Sidewalk. Each individual unit sidewalk designated therefor on the Condominium Subdivision Plan is restricted in use to the Co-Owner of the Unit to which it adjoins.

(e) Unit Driveway. Each individual unit driveway designated therefor on the Condominium Subdivision Plan is restricted in use to the Co-Owner of the Unit to which it adjoins.

(f) Air Conditioner Compressors. Each individual air conditioner compressor, its pad and other equipment and accessories related thereto together with the ground surface immediately below the pad, are restricted in use to the Co-owner of the Unit which such air conditioner compressor services.

(g) Windows, Screens and Doors. The windows, screens and doors in the Project are restricted in use to the Co-owner of the Unit to which such windows, screens and doors are appurtenant.

(h) Garage Doors. The garage door and its hardware shall be limited in use to the Co-owner of the Unit serviced thereby.

(i) Interior Surfaces. The interior surfaces of Unit and garage perimeter walls, ceiling and floors shall be subject to the exclusive use and enjoyment of the Co-owner of such Unit.

(j) Exterior Lighting. The exterior porch lights are limited to the use of the Unit which they serve.

(k) Utility Meters. Utility meters are limited to the Unit served thereby.

(l) Electric, Gas and Water. The electric, gas and water systems from the point of the meter into the Unit which they serve are limited to the Units served thereby.

(m) Heating and Cooling Systems. Each heating and cooling system including, without limitation, all equipment and duct work related thereto are limited to the Unit served thereby.

3. **Responsibilities.** The respective responsibilities for the maintenance, decoration, repair and replacement of the Common Elements are as follows:

(a) General Common Elements. The costs of maintenance, decoration, repair and replacement of all General Common Elements shall be borne by the Association.

(b) Limited Common Elements. The costs of maintenance, decoration, repair and replacement of all Limited Common Elements shall be borne by the Association, except as follows:

(1) ^{front} Porches. The costs of maintenance, repair and replacement referred to in Section 2(a) of this Article shall be borne by the Association; provided however, the Co-owner shall be responsible for removal of snow from the porch appurtenant to its Unit.

(2) ^{BALCONY} Decks. The costs of maintenance, repair and replacement referred to in Section 2(b) of this Article shall be borne by each Unit Co-Owner with respect to its Unit.

(3) [?] Patios. The costs of maintenance, repair and replacement of all patios referred to in Section 2(c) of this Article shall be borne by the Association; provided, however, each Unit Co-Owner shall be responsible for removal of snow from the patio appurtenant to its Unit.

(4) Air Conditioner Compressors. The costs of maintenance, repair and replacement of each air conditioner compressor, its related pad and the ground surface immediately below the same as described in Article IV, Section 2(f) shall be borne by the Co-owner of the Unit such air conditioner compressor services.

(5) Windows and Screens. The repair, replacement and interior maintenance of all window glass and screens referred to in Article IV, Section 2(g) and the costs thereof shall be borne by the Co-owner of the Unit to which any such windows and screens are appurtenant. Exterior maintenance of windows shall be the responsibility of the Association.

(6) Garage Doors. The costs of repair, replacement and maintenance (except in cases of Co-owner fault) of all garage doors referred to in Article IV, Section 2(h) and the costs thereof shall be borne by the Association. In cases of Co-owner fault, the periodicity and the material utilized to repair, replace and maintain garage doors, shall be determined solely by the Association which shall be responsible for performance of the work at the expense of the responsible Co-owner.

(7) Interior Surfaces. The costs of decoration and maintenance (but not repair or replacement except in cases of Co-owner fault) of all interior surfaces referred to in Article IV, Section 2(i) above shall be borne by the Co-owner of each Unit to which such Limited Common Elements are appurtenant.

(8) Exterior Porch Lights. The responsibility for and costs of maintenance, repair and replacement of exterior lights installed by the Developer shall be borne by the Association, except that Co-owners shall be responsible for replacement of bulbs. All replacement bulbs shall be clear glass. Co-owners shall not disable nor tamper with lights operated on photo-cells.

(9) Utility Meters. Co-owners shall be responsible for the maintenance of the utility meters which serve their respective Units.

(10) Electric, Gas and Water Systems. Co-owners shall be responsible for the maintenance, repair and replacement of the electric, gas and water systems from the point of connection to the meter, into and throughout their respective Units, except to the extent such systems shall be contained within General Common Element walls or floors in which case such maintenance, repair and replacement shall be the responsibility of the Association.

(c) Other. The costs of maintenance, repair and replacement of all General and Limited Common Elements other than as described above shall be borne by the Association, subject to any provisions of the Bylaws expressly to the contrary.

(d) Failure of Co-owner to Perform Maintenance Responsibilities. In the event a Co-owner fails to maintain, decorate, repair or replace any items for which he is responsible, the Association (and/or the Developer during the Construction and Sales Period) shall have the right, but not the obligation, to take whatever action or actions it deems desirable to so maintain, decorate, repair and replace any of such Limited Common

Elements, all at the expense of the Co-owner of the Unit. Failure of the Association (or the Developer) to take any such action shall not be deemed a waiver of the Association's (or the Developer's) right to take any such action at a future time. All costs incurred by the Association or the Developer in performing any responsibilities under this Article IV which are required, in the first instance to be borne by any Co-owner, shall be assessed against such Co-owner and shall be due and payable with his monthly assessment next falling due; further, the lien for nonpayment shall attach as in all cases of regular assessments and such assessments may be enforced by the use of all means available to the Association under the Condominium Documents and by law for the collection of regular assessments including, without limitation, legal action, foreclosure of the lien securing payment and imposition of fines.

No Co-owner shall use his Unit or the Common Elements in any manner inconsistent with the purposes of the Project or in any manner which will interfere with or impair the rights of any other Co-owner in the use and enjoyment of his Unit or the Common Elements.

ARTICLE V

UNIT DESCRIPTION AND PERCENTAGE OF VALUE

1. **Description of Units.** Each Unit in the Condominium Project is described in this paragraph with reference to the Condominium Subdivision Plan of RIVER PARK VILLAGE CONDOMINIUM as prepared by McNeely & Lincoln Associates, Inc. Each Unit shall include all that space contained within the interior finished unpainted walls and ceilings and from the finished subfloor and with respect to each Unit garage, all that space contained within the unpainted surface of the garage floor, the interior unfinished walls and the uncovered underside of the garage-roof joists or drywall ceiling covering same, all as shown on the floor plans and sections in the Condominium Subdivision Plan and delineated with heavy outlines. The dimensions shown on basement and foundation plans in the Condominium Subdivision Plan have been or will be physically measured by McNeely & Lincoln Associates, Inc.

2. **Percentage of Value.** The Condominium consists of 38 residential Units. The percentage of value assigned to each Unit is set forth below. The percentage of value assigned to each Unit shall be determinative of each respective share of the Common Elements of the Condominium Project, the proportionate share of each respective Co-owner in the proceeds and the expenses of administration of the Condominium and the value of such Co-owner's vote at meetings of the Association. The total percentage of value of the Project is 100%. Each Unit percentage of value shall be equal and shall be the number obtained by dividing 100 by the number of Units included in the Condominium. The method and formula used by Developer to determine the foregoing percentages was to determine that the expenses incurred by the Association in connection with the various Units should be equal.

ARTICLE VI

CONSOLIDATION AND OTHER MODIFICATIONS

Notwithstanding any other provision of the Master Deed or the Bylaws, Units in the Condominium may be consolidated, modified and the boundaries relocated, in accordance with Sections 48 and 49 of the Act and this Article. Such changes in the affected Unit or Units shall be promptly reflected in a duly recorded amendment or amendments to this Master Deed.

1. **By Developer.** Developer reserves the sole right during the Construction and Sales Period and without the consent of any other Co-owner or any mortgagee of any Unit to take the following action:

(a) **Consolidate Contiguous Units.** Consolidate under single ownership two or more Units which are separated only by Unit perimeter walls. In connection with such consolidation, Developer may alter or remove all or portions of the intervening wall, provided that the structural integrity of the building is not affected

thereby, and provided that no utility connections serving other Units are disturbed other than temporarily. Such consolidation of Units shall be given effect by an appropriate amendment or amendments to this Master Deed in the manner provided by Law, which amendment or amendments shall be prepared by and at the sole discretion of the Developer, its successors or assigns.

(b) Relocate Boundaries. Relocate any boundaries between adjoining Units, separated only by Unit perimeter walls or other Common Elements not necessary for the reasonable use of Units other than those subject to the relocation. In connection with such relocation, Developer may alter or remove all or portions of the intervening wall, provided that the structural integrity of the building is not affected thereby, and provided that no utility connections serving other Units are disturbed other than temporarily. The relocation of such boundaries shall be given effect by an appropriate amendment or amendments to this Master Deed in the manner provided by law, which amendment or amendments shall be prepared by and at the sole discretion of the Developer, its successors or assigns.

(c) Amend to Effectuate Modifications. In any amendments resulting from the exercise of the rights reserved to Developer above, each portion of the Unit or Units resulting from such consolidation or relocation of boundaries shall be separately identified by number. The percentages of value shall be proportionately readjusted in order to preserve a total value of 100% for the entire Project resulting from such amendment to this Master Deed. Such readjustments shall reflect a continuing reasonable relationship among percentages of value based upon the original method of determining percentages of value for the Project. Such amendment or amendments to the Master Deed shall also contain such further definitions of General or Limited Common Elements as may be necessary to describe adequately the Units in the Condominium Project as so modified. All of the Co-owners and mortgagees of Units and other persons interested or to become interested in the Project from time to time shall be deemed to have irrevocably and unanimously consented to such amendment or amendments of this Master Deed to effectuate the foregoing and to any proportionate reallocation of percentages of value of Units which Developer or its successors may determine necessary in conjunction with such amendment or amendments. All such interested persons irrevocably appoint Developer or its successors as agent and attorney for the purpose of execution of such amendment or amendments to the Master Deed and all other documents necessary to effectuate the foregoing. Such amendments may be effected without the necessity of rerecording an entire Master Deed or the Exhibits hereto.

2. By Co-owners. Co-owners of adjoining Units may relocate boundaries between their Units or eliminate boundaries between two or more Units upon written request to and approval by the Association and the Developer during the Construction and Sales Period. Upon receipt of such request, the president of the Association shall present the matter to the Board of Directors for review and, if approved by the Board, cause to be prepared an amendment to the Master Deed duly relocating the boundaries, identifying the Units involved, reallocating percentages of value and providing for conveyancing between or among the Co-owners involved in relocation of boundaries. The Co-owners requesting relocation of boundaries shall bear all costs of such amendment. Such relocation or elimination of boundaries shall not become effective, however, until the amendment to the Master Deed has been recorded in the office of the Oakland County Register of Deeds.

3. Limited Common Elements. Limited Common Elements shall be subject to assignment and reassignment in accordance with Section 39 of the Act and in furtherance of the rights to consolidate or relocate boundaries described in this Article.

ARTICLE VII

[Intentionally omitted.]

ARTICLE VIII

EASEMENTS, RESTRICTIONS AND AGREEMENTS

1. **Easement for Maintenance of Encroachments and Utilities.** In the event any portion of a Unit or Common Element encroaches upon another Unit or Common Element due to shifting, settling or moving of a building, or due to survey errors, or construction deviations, reciprocal easements shall exist for the maintenance of such encroachment for so long as such encroachment exists, and for maintenance thereof after rebuilding in the event of any destruction. There shall be easements to, through and over those portions of the land, structures, buildings, improvements, floors and walls (including interior Unit walls and floors) contained therein for the continuing maintenance and repair of all utilities lines and facilities in the Condominium. There shall exist easements of support with respect to any Unit interior wall which supports a Common Element.

2. **Easements Granted by Developer.** Developer reserves the right at any time during the Construction and Sales Period to grant easements for utilities over, under and across the Condominium to appropriate governmental agencies or public utility companies and to transfer title of utilities to governmental agencies or to utility companies. Any such easement or transfer of title may be conveyed by the Developer without the consent of any Co-owner, mortgagee or other person and shall be evidenced by an appropriate amendment to this Master Deed and to Exhibit B hereto recorded in the Oakland County Records. All of the Co-owners and mortgagees of Units and other persons interested or to become interested in the Project from time to time shall be deemed to have irrevocably and unanimously consented to such amendments to this Master Deed as may be required to effectuate the foregoing grants of easements or transfers of title.

3. **Grants of Easements by Association.** The Association, acting through its lawfully constituted Board of Directors (including any Board of Directors acting prior to the Transitional Control Date) shall be empowered and obligated to grant such easements, licenses, rights-of-entry and rights-of-way over, under and across the Condominium Premises for utility purposes, access purposes or other lawful purposes as may be necessary for the benefit of the Condominium, subject, however, to the approval of the Developer during the Construction and Sales Period.

4. **Easements for Maintenance, Repair and Replacement.** The Developer, the Association and all public or private utility companies shall have such easements over, under, across and through the Condominium Premises, including all Units and Common Elements (including Common Elements located within the interior of any Unit) as may be necessary to develop, construct, market and operate any Units within the land described in Article II hereof, and also to fulfill any responsibilities of maintenance, repair, decoration or replacement which they or any of them are required or permitted to perform under the Condominium Documents or by law, rule or regulation. These easements include, without any implication of limitation, the right of the Association to obtain access during reasonable hours and upon reasonable notice to water meters, sprinkler controls and valves, fire suppression equipment and other Common Elements located within any Unit or its appurtenant Limited Common Elements. The Association shall have an easement to enter all Units at any time, even without notice in the case of an emergency or reasonably perceived emergency in connection with the foregoing purposes.

5. **Telecommunications Agreements.** The Association, acting through its duly constituted Board of Directors and subject to the Developer's approval during the Construction and Sales Period, shall have the power to grant such easements, licenses and other rights of entry, use and access and to enter into any contract or agreement, including wiring agreements, rights-of-way agreements, access agreements and multiunit agreements and, to the extent allowed by law, contracts for sharing of any installation or periodic subscriber service fees as may be necessary, convenient or desirable to provide for telecommunications, videotext, broad band cable, satellite dish, earth antenna and similar services (collectively "Telecommunications") to the Project or any Unit therein. Notwithstanding the foregoing, in no event shall the Board of Directors enter into any contract or agreement or grant any easement, license or right of entry or do any other act or thing which will violate any provision of any federal, state or local law or ordinance. Any and all sums paid by any telecommunications or other company or entity in connection with such service, including fees, if any, for the privilege of installing same or sharing periodic

subscriber service fees, shall be receipts affecting the administration of the Condominium Project within the meaning of the Act and shall be paid over to and shall be the property of the Association.

ARTICLE IX

CONVERTIBLE AREAS

The Condominium is established as a convertible condominium in accordance with the provisions of this Article:

1. The General Common Elements are designated on the Condominium Subdivision Plan as Convertible Areas within which Units and Common Elements may be expanded and modified and within which Limited Common Elements may be created as provided in this Article IX. The Developer reserves the right, but not an obligation, to convert the Convertible Areas. The maximum number of Units that may be created in the Convertible Areas is zero, although Units may be expanded and modified as provided in this Article IX. The number of Units in the Condominium may decrease, but shall not increase, as a result of the conversion of the Convertible Areas.

2. The Developer reserves the right, in its sole discretion, during a period ending 6 years from the date of recording this Master Deed, to modify the size, location, and configuration of any Unit that it owns in the Condominium, and to make corresponding changes to the Common Elements. The changes in the Common Elements could include (by way of illustration and not limitation) construction of court yards, patios, decks, porches and other amenities on any portion of the Convertible Areas.

3. All improvements constructed or installed within the Convertible Areas described above shall be restricted exclusively to residential use and to such Common Elements as are compatible with residential use. There are no other restrictions upon such improvements except those which are imposed by state law, local ordinances or building authorities.

4. The extent to which any structure erected on any portion of the Convertible Areas is compatible with structures included in the original Master Deed is not limited by this Master Deed but lies solely within the discretion of Developer, subject only to the requirements of local ordinances and building authorities.

5. The consent of any Co-owner shall not be required to convert the Convertible Areas. All of the Co-owners and Mortgagees and other persons interested or to become interested in the Condominium from time to time shall be deemed to have irrevocably and unanimously consented to such conversion of the Convertible Areas and any amendment or amendments to this Master Deed to effectuate the conversion and to any reallocation of Percentages of Value of existing Units which Developer may determine necessary in connection with such amendment or amendments. All such interested persons irrevocably appoint the Developer or its successors, as agent and attorney for the purpose of execution of such amendment or amendments to the Master Deed and all other documents necessary to effectuate the foregoing. Such amendments may be effected without the necessity of rerecording the entire Master Deed or the Exhibits thereto and may incorporate by reference all or any pertinent portions of this Master Deed and the Exhibits hereto. Nothing herein contained, however, shall in any way obligate Developer to convert the Convertible Areas. These provisions give notice to all Co-owners, mortgagees and other persons acquiring interests in the Condominium that such amendments of this Master Deed may be made and recorded, and no further notice of such amendment shall be required.

6. All modifications to Units and Common Elements made pursuant to this Article IX shall be given effect by appropriate amendments to this Master Deed in the manner provided by law, which amendments shall be prepared by and at the discretion of the Developer and in which the percentages of value set forth in Article V hereof shall be proportionately readjusted, if the Developer deems it to be applicable, in order to preserve a total

value of 100% for the entire Condominium resulting from such amendments to this Master Deed. The precise determination of the readjustments in percentages of value shall be made within the sole judgment of Developer. Such readjustments, however, shall reflect a continuing reasonable relationship among percentages of value based upon the original method and formula described in Article V of this Master Deed. Such amendments to the Master Deed shall also contain such further definitions and redefinitions of General Common Elements or Limited Common Elements as may be necessary to describe adequately and service the Units and Common Elements being modified by such amendments. In connection with any such amendments, Developer shall have the right to change the nature of any Common Element previously included in the Condominium for any purpose reasonably necessary to achieve the purposes of this Article IX.

ARTICLE X

AMENDMENT

This Master Deed and the Condominium Subdivision Plan may be amended, at all times, with the consent of 66-2/3% of the Co-owners, except as hereinafter set forth:

1. **Modification of Units or Common Elements.** No Unit dimension may be modified in any material adverse way without the consent of the Co-owner and mortgagee of the affected Unit nor may the nature or extent of Limited Common Elements or the responsibility for maintenance, repair or replacement thereof be modified in any material adverse way without the written consent of the Co-owner and mortgagee of the Unit to which the same are appurtenant, except as otherwise expressly provided in this Master Deed or in the Bylaws to the contrary.
2. **Mortgagee Consent.** Whenever a proposed amendment would materially adversely alter or change the rights of mortgagees generally, then such amendments shall require the approval of 66-2/3% of all first mortgagees of record, allocating one vote for each mortgage held.
3. **By Developer.** The Developer may, without the consent of any Co-owner or any other person, amend this Master Deed and the Condominium Subdivision Plan attached as Exhibit B in order to correct survey or other errors made in such documents and to make such other amendments to such instruments and to the Bylaws attached hereto as Exhibit A as do not materially adversely affect any rights of Co-owners or mortgagees in the Project.
4. **Change in Percentage of Value.** The value of the vote of any Co-owner and the corresponding proportion of common expenses assessed against such Co-owner shall not be modified without the written consent of such Co-owner and its mortgagee, nor shall the percentage of value assigned to any Unit be modified without like consent, except as provided in this Master Deed or in the Bylaws.
5. **Termination, Vacation, Revocation or Abandonment.** The Condominium Project may not be terminated, vacated, revoked or abandoned without the written consent of the Developer, 80% of non-developer Co-owners and 80% of the first mortgagees thereof.
6. **Developer Approval.** During the Construction and Sales Period and during the period Developer shall own one or more Units, if longer, the Condominium Documents shall not be amended nor shall the provisions thereof be modified by any other amendment to this Master Deed without the written consent of the Developer.
7. **Amendments for Secondary Market Purposes.** The Developer or Association may amend the Master Deed or Bylaws to facilitate mortgage loan financing for existing or prospective Co-owners and to enable the purchase or insurance of such mortgage loans by the Federal Home Loan Mortgage Corporation, the Federal National Mortgage Association, the Government National Mortgage Association, the Veterans Administration, the Department of Housing and Urban Development, Michigan State Housing Development Authority or by any other

institutional participant in the secondary mortgage market which purchases or insures mortgages. The foregoing amendments may be made without the consent of Co-owners or mortgagees.

8. Amendments for Architectural Purposes. Developer may, without the consent of any Co-owner or any other person, including any mortgagee, amend this Master Deed and the Condominium Subdivision Plan attached as Exhibit B in order to alter the floor plans and/or the elevations and/or the exterior architectural appearance of any buildings and /or Units within the Condominium provided that no such amendment shall increase the size of the applicable building footprint as indicated therefor in the Condominium Subdivision Plan.

Notwithstanding any other provision of this Article X, the method or formula used to determine the percentages of value for Units in the Condominium, as described above, and any provisions relating to the ability or terms under which a Co-owner may rent a Unit to others, may not be modified without the consent of each affected Co-owner and mortgagee.

ARTICLE XI

ASSIGNMENT

Any or all of the rights and powers granted or reserved to the Developer in the Condominium Documents or by law, including the power to approve or disapprove any act, use or proposed action or any other matter or thing, may be assigned by it to any other entity or to the Association. Any such assignment or transfer shall be made by appropriate instrument in writing duly recorded in the office of the Oakland County Register of Deeds.

[Balance of page intentionally blank.]

IN WITNESS WHEREOF, Developer has executed this Master Deed.

WITNESSES:

RIVER PARK VILLAGE BUILDING CO., L.L.C.,
a Michigan limited liability company

J. Adam Rothstein
* J. Adam Rothstein

By: Scott P. Drumm
Scott P. Drumm, Member

Janice Waddell
* Janice Waddell

STATE OF MICHIGAN)
) ss.
COUNTY OF OAKLAND)

On this December 26, 2000, the foregoing Master Deed was acknowledged before me by Scott P. Drumm, a Member of River Park Village Building Co., L.L.C., a Michigan limited liability company, on behalf of the company.

Janice Waddell
* Janice Waddell, Notary Public
Macomb County, MI *
My Commission Expires: 8/12/2004
Acting in Oakland County

Janice Waddell
Notary Public, Macomb County, Michigan
My Commission Expires: August 12, 2004

ACKNOWLEDGMENT AND SUBORDINATION OF BANK

Comerica Bank, the mortgagee of the real property described in the foregoing Master Deed pursuant to the Mortgage dated August 3, 2000 recorded in Liber 21755, Page 473, Oakland County Records, hereby consents to the submission of the real property described in the foregoing Master Deed to the Condominium Project therein described and consents to the recordation of the Master Deed in the land records of the office of the Oakland County Register of Deeds.

WITNESSES:

COMERICA BANK,
a Michigan banking corporation

* Julie Tidmarsh
Julie Tidmarsh
* Marjorie A. Wetzell
MARJORIE A. WETZEL

By: Amanda J. Uffelman
* Amanda J. Uffelman
Its: VICE PRESIDENT

STATE OF MICHIGAN)
) ss.
COUNTY OF Wayne)

On this February 15, 2000, the foregoing Master Deed was acknowledged before me by Amanda Uffelman the Vice President of Comerica Bank, on behalf of the Bank.

* Julie Tidmarsh
 , Notary Public
 County, _____
My Commission Expires: _____

JULIE TIDMARSH
Notary Public - Oakland County, Mich.
Acting in Wayne Co., MI
My Commission Expires 02-28-2002

*Type or print names in BLACK INK beneath signatures.

Drafted by and when recorded return to:

J. Adam Rothstein, Esq.
Honigman Miller Schwartz and Cohn
2290 First National Building
Detroit, Michigan 48226
(313) 465-7530

DET_C1371920.5

**RIVER PARK VILLAGE CONDOMINIUM
NOTICE TO PURCHASERS AND MORTGAGEES**

Re: Private Roads

The roads in River Park Village Condominium are general common elements and, therefore, will be maintained by the River Park Village Homeowners' Association and not by the board of county road commissioners or any other governmental agency.

NOTICE TO PURCHASERS AND MORTGAGEES

Re: Amendments to Master Deed

This is to notify you that the initial Master Deed establishing River Park Village Condominium permits Developer to amend the Master Deed in connection with the conversion of certain areas in the Condominium into units and/or common elements. Such amendments may be made by the Developer in the manner provided in the Master Deed without the consent of Co-owners or mortgagees.

NOTICE TO PURCHASERS AND MORTGAGEES

Re: Chesapeake & Ohio Railroad

The Condominium is situated directly adjacent to a portion of the Chesapeake & Ohio Railroad line. As such, the use of such railroad line for rail traffic may cause dust, noise and vibration that may affect the use and enjoyment of a Unit in the Condominium.

NOTICE TO PURCHASERS AND MORTGAGEES

Re: Former Use

The Condominium Premises were formerly used for other than residential uses including, but not limited to, a powdered milk plant, a stamping plant and a warehouse. According to reports obtained by Developer from duly licensed consultants, the Condominium Premises meet all applicable state law standards for residential use.

DEVELOPER

RIVER PARK VILLAGE BUILDING CO., L.L.C.

EXHIBIT A

BYLAWS

ARTICLE I

ASSOCIATION OF CO-OWNERS

River Park Village Condominium, a residential condominium located in Oakland County, Michigan, shall be administered by an Association of Co-owners which shall be a nonprofit corporation, herein referred to as the "Association", organized under the applicable laws of the State of Michigan, and responsible for the management, maintenance, operation and administration of the Common Elements, easements and affairs of the Condominium in accordance with the Condominium Documents and the laws of the State of Michigan. These Bylaws shall constitute both the Bylaws referred to in the Master Deed and Section 3(8) of the Act and the Bylaws provided for under the Michigan Nonprofit Corporation Act. Each Co-owner shall be entitled to membership and no other person or entity shall be entitled to membership. The share of a Co-owner in the funds and assets of the Association cannot be assigned, pledged or transferred in any manner except as an appurtenance to the Co-owner's Unit. The Association shall keep current copies of the Master Deed, all amendments to the Master Deed and other Condominium Documents for the Condominium available at reasonable hours to Co-owners, prospective purchasers and prospective mortgagees of Units in the Condominium. The Association, all Co-owners in the Condominium and all persons using or entering upon or acquiring any interest in any Unit therein or the Common Elements thereof shall be subject to the provisions and terms set forth in the aforesaid Condominium Documents. All capitalized terms used herein not otherwise defined herein shall have the same meaning as set forth in the Master Deed to which these Bylaws are attached as an exhibit or as set forth in the Act.

ARTICLE II

ASSESSMENTS

The levying of assessments by the Association against the Units and collection of such assessments from the Co-owners in order to pay the expenses arising from the management, administration and operation of the Association shall be governed by the following provisions:

1. Taxes Assessed on Personal Property Owned or Possessed in Common. The Association shall be assessed as the person or entity in possession of any tangible personal property of the Condominium owned or possessed in common by the Co-owners and personal property taxes based thereon shall be treated as expenses of administration.

2. Receipts and Expenditures Affecting Administration. Expenditures affecting administration of the Condominium shall include all costs incurred in satisfaction of any liability arising within, caused by or connected with the Common Elements or the administration of the Condominium. Receipts affecting administration of the Condominium shall include all sums received by the Association as proceeds of, or pursuant to, a policy of insurance securing the interests of the Co-owners against liabilities or losses arising within, caused by or connected with the Common Elements or the administration of the Condominium.

3. Determination of Assessments. Assessments shall be determined in accordance with the following provisions:

(a) The Annual Budget and Regular Monthly Assessments. The Board of Directors of the Association shall establish an annual budget in advance for each fiscal year and such budget shall project all expenses for the forthcoming year which may be required for the proper operation, management and maintenance of

the Condominium, including a reasonable allowance for contingencies and reserves. Upon adoption of an annual budget by the Board of Directors, copies of the budget shall be delivered to each Co-owner and the assessment for said year shall be established based upon said budget, although the failure to deliver a copy of the budget to each Co-owner shall not affect or in any way diminish the liability of any Co-owner for any existing or future assessments. An adequate reserve fund for maintenance, repairs and replacement of those Common Elements that must be replaced on a periodic basis shall be established in the budget and must be funded by regular monthly payments as set forth in Section 5 below rather than by special assessments. At a minimum, the reserve fund shall be equal to 10% of the Association's current annual budget (excluding that portion of the budget allocated to the reserve fund itself on a non-cumulative basis). Since the minimum standard required by this subparagraph may prove to be inadequate, the Association should carefully analyze the Condominium to determine if a greater amount should be set aside, or if additional reserve funds should be established for other purposes from time to time. The Board of Directors shall annually consider the needs of the Condominium to determine if a greater amount should be set aside in reserve or if additional reserve funds should be established for any other purposes. The regular monthly Association assessments provided in this Article II, Section 3(a) shall be levied in the sole discretion of the Board of Directors.

(b) Special Assessments. Special assessments, in addition to those required in subparagraph (a) above, may be made by the Board of Directors from time to time and approved by the Co-owners as hereinafter provided to meet other appropriate requirements of the Association. Special assessments referred to in this subparagraph (b) shall be levied only with the prior approval of more than 60% of all Co-owners in number and in value. The discretionary authority of the Board of Directors to levy assessments pursuant to this subparagraph shall rest solely with the Board of Directors for the benefit of the Association and the members thereof, and shall not be enforceable by any creditors of the Association or of the members thereof.

4. Apportionment of Assessments. Unless otherwise provided herein or in the Master Deed, all assessments levied against the Co-owners to cover expenses of management, administration and operation of the Condominium shall be apportioned among and paid by the Co-owners in accordance with the percentage of value assigned to each Unit in Article V of the Master Deed.

5. Payment of Assessments and Penalty for Default. Annual assessments as determined in accordance with Article II, Section 3(a) above shall be payable by Co-owners in 12 equal monthly installments, commencing with acceptance of a deed to or a land contract vendee's interest in a Unit, or with the acquisition of fee simple title to a Unit by any other means. The payment of an assessment shall be in default if such assessment, or any part thereof, is not paid to the Association in full on or before the due date for such payment. Each installment in default for 10 or more days shall bear interest from the initial due date thereof at the rate of 7% per annum until each installment is paid in full. The Board of Directors may also adopt uniform late charges pursuant to Section 10 of Article VI of these Bylaws. Each Co-owner (whether one or more persons) shall be, and remain, personally liable for the payment of all assessments (including interest, late charges and costs of collection and enforcement of payment) levied against the Unit which may be levied while such Co-owner is the owner thereof, except a land contract purchaser from any Co-owner including the Developer shall be so personally liable and such land contract seller shall not be personally liable for all such assessments levied up to and including the date upon which, if applicable, such land contract seller actually takes possession of the Unit following extinguishment of all rights of the land contract purchaser in the Unit. Payments on account of installments of assessments in default shall be applied as follows: first, to costs of collection and enforcement of payment, including reasonable attorneys' fees; second, to any interest and other charges for late payment on such installments; and third, to installments in default in order of their due dates. A Co-owner selling a Unit shall not be entitled to any refund whatsoever from the Association with respect to any reserve, account or other asset of the Association.

6. Effect of Waiver of Use or Abandonment of Unit. A Co-owner's waiver of the use or enjoyment of any of the Common Elements or abandonment of the Co-owner's Unit shall not exempt the Co-owner from liability for the Co-owner's contribution toward the expenses of administration.

7. Enforcement.

(a) Remedies. In addition to any other remedies available to the Association, the Association may enforce collection of delinquent assessments by a suit at law for a money judgment or by foreclosure of the statutory lien that secures payment of assessments. In the event of default by any Co-owner in the payment of any installment of the annual assessment levied against the Co-owner's Unit, the Association shall have the right to declare all unpaid installments of the annual assessment for the pertinent fiscal year immediately due and payable. The Association may also discontinue the furnishing of any utilities or other services to a Co-owner in default upon seven (7) days' written notice to such Co-owner of its intention to do so. A Co-owner in default shall not be entitled to vote at any meeting of the Association so long as such default continues. In a judicial foreclosure action, a receiver may be appointed to and empowered to take possession of the Unit (if the Unit is not occupied by the Co-owner) and to lease the Unit and collect and apply the rental therefrom. All of these remedies shall be cumulative and not alternative.

(b) Foreclosure Proceedings. Each Co-owner, and every other person who from time to time has any interest in the Condominium, shall be deemed to have granted to the Association the unqualified right to elect to foreclose the statutory lien that secures payment of assessments either by judicial action or by advertisement. The provisions of Michigan law pertaining to foreclosure of mortgages by judicial action and by advertisement, as the same may be amended from time to time, are incorporated herein by reference for the purposes of establishing the alternative procedures to be followed in lien foreclosure actions and the rights and obligations of the parties to such actions. Further, each Co-owner and every other person who from time to time has any interest in the Condominium shall be deemed to have authorized and empowered the Association to sell or cause to be sold the Unit with respect to which the assessment(s) is or are delinquent to receive, hold and distribute the proceeds of such sale in accordance with the priorities established by Michigan law. The Association, acting on behalf of all Co-owners may bid at the foreclosure sale, and acquire, hold, lease, mortgage or convey the Unit sold.

(c) Notice of Action. The Association may not commence proceedings to foreclose a lien for unpaid assessments without recording and serving a notice of lien in the following manner:

(i) The notice of lien shall set forth the legal description of the Condominium Unit or Units to which the lien attaches, the name of the Co-owner of record thereof, the amount due the Association as of the date of the notice, exclusive of interest, costs, attorneys fees and future assessments.

(ii) The notice of lien shall be in recordable form, executed by an authorized representative of the Association and may contain such other information as the Association deems appropriate.

(iii) The notice of lien shall be recorded in the office of the register of deeds in the county in which the Condominium is situated and shall be served upon the delinquent Co-owner by first class mail postage prepaid, addressed to the last known address of the Co-owner at least 10 days in advance of the commencement of the foreclosure proceedings.

(d) Expenses of Collection. The expenses incurred in collecting unpaid assessments, including interest, costs, actual attorneys' fees (not limited to statutory fees) and advances for taxes or other liens paid by the Association to protect its lien, plus any late charges, shall be chargeable to the Co-owner in default and shall be secured by the lien on the Unit.

8. Liability of Mortgagee. Notwithstanding any other provisions of the Condominium Documents, if the mortgagee of a first mortgage of record or other purchaser of a Condominium Unit obtains title to the Condominium Unit as a result of foreclosure of the first mortgage, such person, its successors and assigns, is not liable for the assessments by the Association chargeable to the Unit which became due prior to the acquisition of title to the Unit by such person and the expiration of the period of redemption from such foreclosure. The unpaid assessments are deemed to be common expenses collectible from all of the Condominium Unit Co-owners including

such persons, its successors and assigns.

9. Developer's Responsibility for Assessments. Notwithstanding any other provisions of the Condominium Documents to the contrary, Developer shall not pay regular monthly Association assessments for Units which are owned by Developer but unoccupied, but shall only reimburse the Association for actual expenses incurred by the Association which are reasonably allocable to such Units. Developer shall in no event be liable for any assessment levied in whole or in part to purchase any Unit from Developer or to finance any litigation or other claims against Developer, any cost of investigating and preparing such litigation or claim or any similar or related costs.

10. Unpaid Assessments Due on Unit Sale; Statement of Unpaid Assessments. Upon the sale or conveyance of a Condominium Unit, all unpaid assessments against the Condominium Unit shall be paid out of the sale price or by the purchaser in preference over any other assessments or charges of whatever nature except (a) amounts due the State of Michigan or any subdivision thereof for taxes or special assessments due and unpaid on the Unit, and (b) payments due under first mortgages having priority thereto. A purchaser of a Condominium Unit is entitled to a written statement from the Association setting forth the amount of unpaid assessments outstanding against the Unit and the purchaser is not liable for any unpaid assessment in excess of the amount set forth in such written statement nor shall the Unit be subject to any lien for any amounts in excess of the amount set forth in the written statement. Any purchaser or grantee who fails to request a written statement from the Association as provided herein at least five days before the sale, or to pay any unpaid assessments against the Unit at the closing of the Unit purchase if such a statement was requested, shall be liable for any unpaid assessments against the Unit together with interest, costs and attorneys' fees incurred in connection with the collection thereof.

11. Property Taxes and Special Assessments. All property taxes and special assessments levied by any public taxing authority shall be assessed in accordance with Section 131 of the Act.

12. Construction Liens. A construction lien otherwise arising under Act No. 497 of the Michigan Public Acts of 1980, as amended, shall be subject to Section 132 of the Act.

ARTICLE III

JUDICIAL ACTIONS AND CLAIMS

Actions on behalf of and against the Co-owners shall be brought in the name of the Association. Subject to the express limitations on actions in these Bylaws and in the Association's Articles of Incorporation, the Association may assert, defend or settle claims on behalf of all Co-owners in connection with the Common Elements of the Condominium. As provided in the Articles of Incorporation of the Association, the commencement of any civil action (other than one to enforce these Bylaws or collect delinquent assessments) shall require the approval of a majority in number and in value of the Co-owners, and shall be governed by the requirements of this Article III. The requirements of this Article III will ensure that the Co-owners are fully informed regarding the prospects and likely costs of any civil action the Association proposes to engage in, as well as the ongoing status of any civil actions actually filed by the Association. These requirements are imposed in order to reduce both the cost of litigation and the risk of improvident litigation, and in order to avoid the waste of the Association's assets in litigation where reasonable and prudent alternatives to the litigation exist. Each Co-owner shall have standing to sue to enforce the requirements of this Article III. The following procedures and requirements apply to the Association's commencement of any civil action other than an action to enforce these Bylaws or to collect delinquent assessments:

1. Board of Directors' Recommendation to Co-owners. The Association's Board of Directors shall be responsible in the first instance for recommending to the Co-owners that a civil action be filed, and supervising and directing any civil actions that are filed.

2. Litigation Evaluation Meeting. Before an attorney is engaged for purposes of filing a civil action on behalf of the Association, the Board of Directors shall call a special meeting of the Co-owners ("litigation evaluation meeting") for the express purpose of evaluating the merits of the proposed civil action. The written notice to the Co-owners of the date, time and place of the litigation evaluation meeting shall be sent to all Co-owners not less than twenty (20) days before the date of the meeting and shall include the following information copied onto 8-1/2" x 11" paper:

(a) A certified resolution of the Board of Directors setting forth in detail the concerns of the Board of Directors giving rise to the need to file a civil action and further certifying that:

- (1) it is in the best interests of the Association to file a lawsuit;
- (2) that at least one member of the Board of Directors has personally made a good faith effort to negotiate a settlement with the putative defendant(s) on behalf of the Association, without success;
- (3) litigation is the only prudent, feasible and reasonable alternative; and
- (4) the Board of Directors' proposed attorney for the civil action is of the written opinion that litigation is the Association's most reasonable and prudent alternative.

(b) A written summary of the relevant experience of the attorney ("litigation attorney") the Board of Directors recommends be retained to represent the Association in the proposed civil action, including the following information:

- (1) the number of years the litigation attorney has practiced law; and
- (2) the name and address of every condominium and homeowner association for which the attorney has filed a civil action in any court, together with the case number, county and court in which each civil action was filed.

(c) The litigation attorney's written estimate of the amount of the Association's likely recovery in the proposed lawsuit, net of legal fees, court costs, expert witness fees and all other expenses expected to be incurred in the litigation.

(d) The litigation attorney's written estimate of the cost of the civil action through a trial on the merits of the case ("total estimated cost"). The total estimated cost of the civil action shall include the litigation attorney's expected fees, court costs, expert witness fees, and all other expenses expected to be incurred in the civil action.

(e) The litigation attorney's proposed written fee agreement.

(f) The amount to be specially assessed against each Unit in the Condominium to fund the estimated cost of the civil action both in total and on a monthly per Unit basis, as required by Section 6 of this Article III.

3. Independent Expert Opinion. If the lawsuit relates to the condition of any of the Common Elements of the Condominium, the Board of Directors shall obtain a written independent expert opinion as to reasonable and practical alternative approaches to repairing the problems with the Common Elements, which shall set forth the estimated costs and expected viability of each alternative. In obtaining the independent expert opinion required by the preceding sentence, the Board of Directors shall conduct its own investigation as to the

qualifications of any expert and shall not retain any expert recommended by the litigation attorney or any other attorney with whom the Board of Directors consults. The purpose of the independent expert opinion is to avoid any potential confusion regarding the condition of the Common Elements that might be created by a report prepared as an instrument of advocacy for use in a civil action. The independent expert opinion will ensure that the Co-owners have a realistic appraisal of the condition of the Common Elements, the likely cost of repairs to or replacement of the same, and the reasonable and prudent repair and replacement alternatives. The independent expert opinion shall be sent to all Co-owners with the written notice of the litigation evaluation meeting.

4. Fee Agreement with Litigation Attorney. The Association shall have a written fee agreement with the litigation attorney, and any other attorney retained to handle the proposed civil action. The Association shall not enter into any fee agreement that is a combination of the retained attorney's hourly rate and a contingent fee arrangement unless the existence of the agreement is disclosed to the Co-owners in the text of the Association's written notice to the Co-owners of the litigation evaluation meeting.

5. Co-Owner Vote Required. At the litigation evaluation meeting the Co-owners shall vote on whether to authorize the Board of Directors to proceed with the proposed civil action and whether the matter should be handled by the litigation attorney. The commencement of any civil action by the Association (other than a suit to enforce these Bylaws or collect delinquent assessments) shall require the approval of a 66-2/3% in value of the Co-owners. Notwithstanding anything herein to the contrary, no proxy voting shall be permitted in connection with any such vote.

6. Litigation Special Assessment. All legal fees incurred in pursuit of any civil action that is subject to Section 1 through 10 of this Article III shall be paid by special assessment of the Co-owners ("litigation special assessment"). The litigation special assessment shall be approved at the litigation evaluation meeting (or at any subsequent duly called and noticed meeting) by a majority in number and in value of all Co-owners in the amount of the estimated total cost of the civil action. If the litigation attorney proposed by the Board of Directors is not retained, the litigation special assessment shall be in an amount equal to the estimated total cost of the civil action, as estimated by the attorney actually retained by the Association. The litigation special assessment shall be apportioned to the Co-owners in accordance with their respective percentage of value interests in the Condominium and shall be collected from the Co-owners on a monthly basis. The total amount of the litigation special assessment shall be collected monthly over a period not to exceed twenty-four (24) months.

7. Attorney's Written Report. During the course of any civil action authorized by the Co-owners pursuant to this Article IX, the retained attorney shall submit a written report ("attorney's written report") to the Board of Directors every thirty (30) days setting forth:

(a) The attorney's fees, the fees of any experts retained by the attorney, and all other costs of the litigation during the thirty (30) day period immediately preceding the date of the attorney's written report ("reporting period").

(b) All actions taken in the civil action during the reporting period, together with copies of all pleadings, court papers and correspondence filed with the court or sent to opposing counsel during the reporting period.

(c) A detailed description of all discussions with opposing counsel during the reporting period, written and oral, including, but not limited to, settlement discussions.

(d) The costs incurred in the civil action through the date of the written report, as compared to the attorney's estimated total cost of the civil action.

(e) Whether the originally estimated total cost of the civil action remains accurate.

8. Monthly Board Meetings. The Board of Directors shall meet monthly during the course of any civil action to discuss and review:

- (a) the status of the litigation;
- (b) the status of settlement efforts, if any; and
- (c) the attorney's written report.

9. Changes in the Litigation Special Assessment. If, at any time during the course of a civil action, the Board of Directors determines that the originally estimated total cost of the civil action or any revision thereof is inaccurate, the Board of Directors shall immediately prepare a revised estimate of the total cost of the civil action. If the revised estimate exceeds the litigation special assessment previously approved by the Co-owners, the Board of Directors shall call a special meeting of the Co-owners to review the status of the litigation, and to allow the Co-owners to vote on whether to continue the civil action and increase the litigation special assessment. The meeting shall have the same quorum and voting requirements as a litigation evaluation meeting.

10. Disclosure of Litigation Expenses. The attorneys' fees, court costs, expert witness fees and all other expenses of any civil action filed by the Association ("litigation expenses") shall be fully disclosed to Co-owners in the Association's annual budget. The litigation expenses for each civil action filed by the Association shall be listed as a separate line item captioned "litigation expenses" in the Association's annual budget.

ARTICLE IV

INSURANCE

1. Extent of Coverage. The Association shall carry fire and extended coverage, vandalism and malicious mischief and liability insurance and worker's compensation insurance, if applicable, pertinent to the ownership, use and maintenance of the Common Elements, and such other insurance as the Board of Directors deems advisable, and all such insurance shall be carried and administered in accordance with the following provisions:

(a) Responsibilities of Co-owners and Association. All such insurance shall be purchased by the Association for the benefit of the Association, and the Co-owners and their mortgagees, as their interests may appear, and provision shall be made for the issuance of certificates of mortgagee endorsements to the mortgagees of Co-owners. Co-owners may obtain additional insurance upon their Units, at their own expense, in addition to the coverage carried by the Association. It shall be each Co-owner's responsibility to obtain insurance coverage for personal property located within a Unit or elsewhere in the Condominium and for personal liability for occurrences within a Unit or upon Limited Common Elements appurtenant to a Unit and also for alternative living expense in event of fire, and the Association shall have absolutely no responsibility for obtaining such coverages. The Association and all Co-owners shall use their best efforts to obtain property and liability insurance containing appropriate provisions whereby the insurer waives its right of subrogation as to any claims against any Co-owner or the Association.

(b) Amount of Insurance on Common Elements. All Common Elements of the Condominium shall be insured against fire and other perils covered by a standard extended coverage endorsement, in an amount equal to the appropriate percentage of maximum insurable replacement value, excluding foundation and excavation costs, as determined annually by the Board of Directors of the Association. Such coverage shall also include interior walls within any Unit and the pipes, wires, conduits and ducts contained therein and shall further include all fixtures, equipment and trim within a Unit which were furnished by Developer with the Unit, or replacements of such improvements made by a Co-owner within a Unit. Any other improvements made by a Co-

owner within a Unit shall be covered by insurance obtained by and at the expense of said Co-owner; provided that, if the Association elects to include such improvements under its insurance coverage, any additional premium cost to the Association attributable thereto may be assessed to and borne solely by said Co-owner and collected as part of the assessments against said Co-owner under Article II hereof.

(c) Premium Expenses. All premiums on insurance purchased by the Association pursuant to these Bylaws shall be expenses of administration.

(d) Proceeds of Insurance Policies. Proceeds of all insurance policies owned by the Association shall be received by the Association, held in a separate account and distributed to the Association and the Co-owners and their mortgagees, as their interests may appear; provided, however, whenever repair or reconstruction of the Condominium shall be required as provided in Article V of these Bylaws, the proceeds of any insurance received by the Association as a result of any loss requiring repair or reconstruction shall be applied for such repair or reconstruction and in no event shall hazard insurance proceeds be used for any purpose other than for repair, replacement or reconstruction of the Condominium unless all of the institutional holders of first mortgages on Units in the Condominium have given their prior written approval.

2. Authority of Association to Settle Insurance Claims. Each Co-owner, by ownership of a Unit in the Condominium, shall be deemed to appoint the Association as the Co-owner's true and lawful attorney-in-fact to act in connection with all matters concerning the maintenance of fire and extended coverage, vandalism and malicious mischief, liability insurance and workmen's compensation insurance, if applicable, pertinent to the Condominium, with such insurer as may, from time to time, be designated to provide such insurance for the Condominium. Without limitation on the generality of the foregoing, the Association as said attorney shall have full power and authority to purchase and maintain such insurance, to collect and remit premiums therefor, to collect proceeds and to distribute the same to the Association, the Co-owners and respective mortgagees, as their interests may appear (subject always to the Condominium Documents), to execute releases of liability and to execute all documents and to do all things on behalf of such Co-owner and the Condominium as shall be necessary or convenient to the accomplishment of the foregoing.

ARTICLE V

RECONSTRUCTION OR REPAIR

1. Reconstruction or Repair Unless Unanimous Vote to the Contrary. If any part of the Condominium shall be partially or completely destroyed, it shall be reconstructed or repaired unless it is determined by a unanimous vote of all Co-owners that the Condominium shall be terminated and each institutional holder of a first mortgage lien on any Unit in the Condominium has given prior written approval of such termination.

2. Repair in Accordance with Master Deed and Plans and Specifications. Any such reconstruction or repair shall be substantially in accordance with the Master Deed and the plans and specifications for the Condominium to a condition as comparable as possible to the condition existing prior to damage unless the Co-owners shall unanimously decide otherwise.

3. Responsibility for Reconstruction and Repair. If the damage is only to a part of a Unit which is the responsibility of a Co-owner to maintain and repair, it shall be the responsibility of the Co-owner to repair such damage in accordance with Section 4 hereof. In all other cases, the responsibility for reconstruction and repair shall be that of the Association.

4. Damage to Part of Unit Which a Co-owner Has the Responsibility to Repair. Each Co-owner shall be responsible for the reconstruction and repair of the interior of the Co-owner's Unit, including, but not limited to,

floor coverings, wall coverings, window shades, draperies, interior walls (but not any Common Elements therein), interior trim, furniture, light fixtures and all appliances, whether free standing or built-in. In the event damage to any of the foregoing, or in interior walls within a Co-owner's Unit or to pipes, wires, conduits, ducts or other Common Elements therein is covered by insurance held by the Association, then the reconstruction or repair shall be the responsibility of the Association in accordance with Section 5 of this Article. If any other interior portion of a Unit is covered by insurance held by the Association for the benefit of the Co-owner, the Co-owner shall be entitled to receive the proceeds of insurance relative thereto, and if there is a mortgagee endorsement, the proceeds shall be payable to the Co-owner and the mortgagee jointly. In the event of substantial damage to or destruction of any Unit or any part of the Common Elements, the Association promptly shall so notify each institutional holder of a first mortgage lien on any Unit in the Condominium.

5. Association Responsibility for Reconstruction and Repair. The Association shall be responsible for the reconstruction and repair of the Common Elements (except as specifically otherwise provided in the Master Deed) and any incidental damage to a Unit caused by such Common Elements or the reconstruction and repair thereof. Immediately after a casualty causing damage to property for which the Association has the responsibility of repair and reconstruction, the Association shall obtain reliable and detailed estimates of the cost to replace the damaged property in a condition as good as that existing before the damage. If the proceeds of insurance are not sufficient to defray the estimated costs of reconstruction or repair required to be performed by the Association, or if at any time during such reconstruction or repair, or upon completion of such reconstruction or repair, the funds for the repayment of the costs thereof are insufficient, assessments shall be made against all Co-owners for the cost of reconstruction or repair of the damaged property in sufficient amounts to provide funds to pay the estimated or actual cost of repair. This provision shall not be construed to require replacement of mature trees and vegetation with equivalent trees or vegetation. Assessments pursuant to this Article V, Section 5 may be made by the Association without a vote of the Co-owners.

6. Timely Reconstruction and Repair. Subject to Section 1 of this Article V, if damage to Common Elements or a Unit adversely affects the appearance of the Condominium, the Association or Co-owner responsible for the reconstruction and repair thereof shall proceed with replacement of the damaged property without delay.

7. Eminent Domain. The following provisions shall control upon any taking by eminent domain:

(a) The provisions of Section 133 of the Condominium Act of Michigan shall apply.

(b) In the event the Condominium continues after a taking by eminent domain, the remaining portion of the Condominium shall be re-surveyed and the Master Deed amended accordingly by the Association.

(c) In the event any Unit in the condominium, or any portion thereof, or the Common Elements or any portion thereof, is made the subject matter of any condemnation or eminent domain proceeding or is otherwise sought to be acquired by a condemning authority, the Association promptly shall so notify each institutional holder of a first mortgage lien on any of the Units in the Condominium.

8. Notices to Certain Mortgagees. In the event any mortgage in the Condominium is held by the Federal Home Loan Mortgage Corporation ("FHLMC"), or in the event any mortgage is held by or insured by the United States Department of Housing and Urban Development ("HUD"), the Association shall give FHLMC and HUD written notice at such address as it may from time to time direct of any loss to or taking of the Common Elements of the Condominium, or any loss to or taking of any Unit, or part thereof, if the loss or taking exceeds \$10,000 in amount.

9. Priority of Mortgagees in Proceeds. Nothing contained in the Condominium Documents shall be construed to give a Co-owner or any other party priority over any rights of first mortgagees of Condominium Units pursuant to their mortgages in the case of a distribution to Condominium Unit owners of insurance proceeds or

condemnation awards for losses to or a taking of Condominium Units and/or Common Elements.

ARTICLE VI

RESTRICTIONS

1. Uses Permitted. No Unit shall be used for other than residential purposes. No Co-owner shall carry on any commercial activities anywhere on the premises of the Condominium. Notwithstanding the foregoing, Developer may conduct any of the activities expressly described in the Master Deed or its exhibits.

2. Alterations and Modifications. No Co-owner shall make alterations in exterior appearance or make structural modifications to any Unit (including interior walls through or in which there exist easements for support or utilities) or make changes in any of the Common Elements limited or generally without the express written approval of the Board of Directors including but not limited to, exterior painting or the erection of decks, antennas, lights, aerials, awnings, doors, shutters or other exterior attachments or modifications; nor shall any Co-owner damage or make modifications or attachments to Common Element walls between Units which in any way impair sound conditioning qualities of the walls. The Board of Directors may approve only such modifications as do not impair the soundness, safety, utility or appearance of the Condominium.

3. Activities. No immoral, improper, unlawful or offensive activity shall be carried on in any Unit or upon the Common Elements, nor shall anything be done which may be or become an annoyance or a nuisance to the Co-owners of the Condominium, nor shall any unreasonably noisy activity be carried on in or on the Common Elements or within any Unit at any time. No Co-owner shall do or permit anything to be done or keep or permit to be kept in the Co-owner's Unit or on the Common Elements anything that will increase the rate of insurance on the Condominium without the written approval of the Association, and each Co-owner shall pay to the Association the increased cost of insurance premiums resulting from any such activity or the maintenance of any such condition even if improved, which increased cost may be assessed to and collected from the Co-owner in the manner provided in Article II hereof.

4. Animals or Pets. Without the prior written consent of the Board of Directors, no animal or pet other than two cats or two dogs or one cat and one dog, each not to exceed 60 pounds in weight, shall be kept in the Condominium with respect to any one Unit by the Co-owner or Co-owners thereof. Any pets kept in the Condominium shall have such care and restraint as not to be obnoxious on account of noise, odor or unsanitary conditions. No savage or dangerous animal shall be kept. No birds which emit loud or obnoxious noises shall be kept. No animal may be permitted to run loose upon the Common Elements and any animal shall at all times be attended by a responsible person while on the Common Elements. Any person who causes or permits an animal to be brought or kept on the Condominium property shall indemnify and hold harmless the Association for any loss, damage or liability which the Association may sustain as a result of the presence of such animal on the Condominium property. The term "animal or pet" as used in this Section shall not include small animals which are constantly caged such as small birds or fish. All pets must be registered with the Board of Directors of the Association.

5. Aesthetics. The Common Elements shall not be used for storage of supplies, materials, personal property or trash or refuse of any kind, except as provided in the Master Deed or in duly adopted rules and regulations of the Associations. All rubbish, trash, garbage and other waste shall be regularly removed from each Unit and shall not be allowed to accumulate therein. Unless special areas are designated by the Association, trash receptacles shall not be permitted on the Common Elements except for such short periods of time as may be reasonably necessary to permit periodic collection of trash. All interior window treatments within any Unit shall be of an off-white color and shall be approved by the Association prior to installation so that all such window treatments shall effect a uniform look throughout the Condominium. The Common Elements and the porches and

any decks appurtenant to any Unit shall not be used in any way for the drying, shaking, or airing of clothing or other fabrics. Automobiles may only be washed in areas approved by the Board of Directors. In general, no activity shall be carried on nor condition maintained by a Co-owner, either in a Unit or upon the Common Elements, which is detrimental to the appearance of the Condominium.

6. Common Elements. Each driveway leading into a garage may only be used by the Co-owner entitled to use the garage. The Common Elements shall not be obstructed in any way nor shall they be used for purposes other than for which they are reasonably and obviously intended. No Co-owner may leave personal property of any description (including by way of example and not limitation bicycles, vehicles, chairs and benches) unattended on or about the Common Elements. Use of all General Common Elements may be limited to such times and in such manner as the Board of Directors shall determine by duly adopted regulations.

7. Vehicles. No house trailers, commercial vehicles, boat trailers, boats, camping vehicles, camping trailers, snowmobiles, snowmobile trailers, recreational vehicles or vehicles other than automobiles and/or motorcycles may be parked or stored upon the Common Elements, unless parked in an area specifically designated therefor by the Board of Directors.

8. Weapons. No Co-owner shall use, or permit the use by any occupant, agent, employee, invitee, guest or member of his or her family of any firearms, air rifles, pellet guns, B-B guns, bows and arrows, sling shots or other similar weapons, projectiles or devices anywhere on or about the Condominium.

9. Signs and Advertising. No signs or other advertising devices shall be displayed which are visible from the exterior of a Unit or on the Common Elements, including "For Sale" signs, without written permission from the Board of Directors. To the extent permitted, "For Sale" signs shall not exceed 2 feet x 2 feet and shall be black and gold in color.

10. Rules and Regulations. Reasonable regulations consistent with all laws and the Condominium Documents concerning the use of the Common Elements or the rights and responsibilities of the Co-owners and the Association with respect to the Condominium or the manner of operation of the Association and of the Condominium may be made and amended from time to time by any Board of Directors of the Association, including the first Board of Directors or its successors) prior to the Transitional Control Date. Copies of all such rules, regulations and amendments thereto shall be furnished to all Co-owners or posted on General Common Element. Any such rule, regulation or amendment may be revoked at any time by the affirmative vote of a majority of the Co-owners.

11. Association's Right of Access. The Association or its duly authorized agents shall have access to each Unit and any Limited Common Elements appurtenant thereto from time to time, during reasonable working hours, upon notice to the Co-owner thereof as may be necessary for the maintenance, repair or replacement of any of the Common Elements. The association or its agent shall also have access to each Unit and any Limited Common Elements appurtenant thereto at all times without notice as may be necessary to make emergency repairs to prevent damage to the Common Elements or to another Unit. It shall be the responsibility of each Co-owner to provide the Association means of access to the Co-owner's Unit and any Limited Common Elements appurtenant thereto during all periods of absence and in the event of the failure of such Co-owner to provide means of access, the Association may gain access in such manner as may be reasonable under the circumstances and shall not be liable to such Co-owner for any necessary damage to any Unit or any Limited Common Elements appurtenant thereto caused thereby or for repair or replacement of such damage. Subject to the foregoing and other provisions in the Master Deed and these Bylaws, each Co-owner shall be entitled to exclusive occupancy and control over the Co-owner's Unit and all Limited Common Elements appurtenant thereto.

12. Common Element Maintenance. No unsightly condition shall be maintained upon any deck, patio or porch and only furniture and equipment consistent with ordinary deck, patio or porch use shall be permitted to remain there during seasons when the same are reasonably in use and no furniture or equipment of any kind shall be

stored on decks, patios or porches during seasons when the same are not reasonably in use. Porch and deck furniture, if any, shall be kept in good condition and repair and shall be in an off-white or hunter green color or, if made from wood, a natural or stained wood color, only.

13. Co-Owner Maintenance. Each Co-owner shall maintain the Unit owned and any Limited Common Elements appurtenant thereto for which the Co-owner has maintenance responsibility in a safe, clean and sanitary condition. Each Co-owner shall also use due care to avoid damaging any of the Common Elements including but not limited to the telephone, water, gas, plumbing, electrical or other utility conduits and systems and any other elements in any Unit which are appurtenant to or which may affect any other Unit. Each Co-owner shall be responsible for damages or costs of the Association resulting from negligent damage to or misuse of any of the Common Elements by the Co-owner or the Co-owner's family, guests, agents or invitees, unless such damages or costs are covered by insurance carried by the Association in which case there shall be no such responsibility, unless reimbursement to the Association is excluded by virtue of a deductible provision, in which case the responsible Co-owner shall bear the expense to the extent of the deductible amount. Any costs or damages to the Association may be assessed to and collected from the responsible Co-owner in the manner provided in Article II hereof.

14. Reserved Rights of Developer.

(a) Prior Approval by Developer. As long as Developer owns any Unit which Developer offers for sale, no buildings, fences, walls, retaining walls, decks, drives, walks or other structures or improvements shall be commenced, erected, maintained, nor shall any addition to, or change or alteration to any structure be made (including in color or design), except interior alterations which do not affect structural elements of any Unit, nor shall any hedges, trees or substantial plantings or landscaping modifications be made, until plans and specifications, acceptable to Developer, showing the nature, kind, shape, height, materials, color, scheme, location and approximate cost of such structure or improvement and the grading or landscaping plans of the area to be affected shall have been submitted to and approved in writing by Developer, its successors or assigns, and a copy of said plans and specifications, as finally approved, lodged permanently with Developer. Developer shall have the right to refuse to approve any such plans or specifications and grading or landscaping plans which are not suitable or desirable in its opinion for aesthetic or other reasons; and, in passing upon such plans, specifications, grading or landscaping plans, it shall have the right to take into consideration the suitability of the proposed structure, improvement or modification, the site upon which it is proposed to effect the same and the degree of harmony thereof with the Condominium as a whole and any adjoining properties under development or proposed to be developed by Developer. The purpose of this Section is to assure the continued maintenance of the Condominium as a beautiful and harmonious residential development and shall be binding upon both the Association and upon all Co-owners.

(b) Developer's Rights in Furtherance of Development and Sales. None of the restrictions contained in this Article VI shall apply to the commercial activities or signs or billboards of Developer with respect to unoccupied Units owned by Developer, or of the Association in furtherance of its powers and purposes. Notwithstanding anything to the contrary elsewhere herein contained, until all Units in the entire planned Condominium are sold by Developer, Developer shall have the right to maintain a sales office, a business office, a construction office, model units, storage areas and reasonable parking incident to the foregoing and such access to, from and over the Condominium as may be reasonable to enable development and sale of the entire Condominium by the Developer and Developer shall have the right to use any model units within the Condominium in connection with the sales activities of its affiliates at other unrelated condominium, townhome or other developments owned and/or operated by Developer or such affiliates.

(c) Enforcement of Bylaws. The Condominium shall at all times be maintained in a manner consistent with the highest standards of a beautiful, serene, private residential community for the benefit of the Co-owners and all persons having interests in the Condominium. If at any time the Association fails or refuses to carry out its obligation to maintain, repair, replace and landscape in a manner consistent with the maintenance of such high standards, then Developer, or any entity to which it may assign this right, at its option, may elect to maintain, repair and/or replace any Common Elements and/or to do any landscaping required by these Bylaws and to charge

the cost thereof of the Association as an expense of administration. Developer shall have the right to enforce these Bylaws so long as Developer owns any Unit which Developer (or its affiliates) offers for sale or uses as a model Unit, which right of enforcement shall include without limitation an action to restrain the Association or any Co-owner from any activity prohibited by these Bylaws.

15. Leasing and Rental. Co-owners, including Developer, may rent any number of Units at any time for any term of occupancy not less than one year subject to the following:

(a) Disclosure of Lease Terms to Association. A Co-owner, including the Developer, desiring to rent or lease a Unit shall disclose that fact in writing to the Association at least 10 days before presenting a lease form to a potential lessee and, at the same time, shall supply the Association with a copy of the exact lease form for its review for compliance with the Condominium Documents. If Developer desires to rent Units before the Transitional Control Date, it shall, notify either the Advisory Committee or each Co-owner in writing.

(b) Compliance with Condominium Documents. Tenants and non-owner occupants shall comply with all of the conditions of the Condominium Documents and all leases and rental agreements shall so state.

(c) Procedures in the Event of Non-Compliance with Condominium Documents. If the Association determines that the tenant or non-owner occupant has failed to comply with the conditions of the Condominium Documents, the Association shall take the following action:

(i) The Association shall notify the Co-owner by certified mail advising of the alleged violation by the tenant or non-owner occupant.

(ii) The Co-owner shall have 15 days (or such additional time as may be granted by the Association if the Co-owner is diligently proceeding to cure) after receipt of such notice to investigate and correct the alleged breach by the tenant or non-owner occupant or advise the Association that a violation has not occurred.

(iii) If after 15 days the Association believes that the alleged breach is not cured or may be repeated, it may institute on its behalf or derivatively by the Co-owners on behalf of the Association, if it is under the control of the Developer, an action for both eviction against the tenant or non-owner occupant and, simultaneously, for money damages against the Co-owner and tenant or non-owner occupant for breach of the conditions of the Condominium Documents. The relief provided for in this subparagraph may be by summary proceeding. The Association may hold both the tenant or non-owner occupant and the Co-owner liable for any damages to the Common Elements caused by the Co-owner or tenant or non-owner occupant in connection with the Unit or Condominium.

(d) Notice to Co-owner's Tenant Permitted Where Co-owner is in Arrears to the Association for Assessments. When a Co-owner is in arrears to the Association for assessments, the Association may give written notice of the arrearage to a tenant or non-owner occupant occupying a Co-owner's Unit under a lease or rental agreement and the tenant, or non-owner occupant after receiving the notice, shall deduct from rental payments due the Co-owner the arrearage and future assessments as they fall due and pay them to the Association. The deductions shall not constitute a breach of the rental agreement or lease by the tenant.

16. Assessment of Fines. The violation of any of the provisions of these Bylaws and/or of the Master Deed, including any of the rules and regulations promulgated by the Board of Directors of the Association hereunder, by any Co-owner (other than Developer), or a tenant or occupant of such Co-owner's Unit, shall be grounds for assessment by the Association of a monetary fine for such violation against such Co-owner. No fine may be assessed unless the rules and regulations establishing such fine have first been duly adopted by the Board of Directors of the Association, notice thereof has been given to all Co-owners and such rules and regulations are

applicable equally to all Co-owners (other than Developer). Thereafter, fines may be assessed only upon notice to the offending Co-owner and an opportunity for such Co-owner to appear before the Board no less than seven days from the date of the notice and offer evidence in defense of the alleged violation. Upon finding an alleged violation after an opportunity for hearing has been provided, the Board may levy a fine in such amount as it, in its discretion, deems appropriate and/or as is set forth in the rules and regulations establishing the fine procedure. The Board may find that a violation of these Bylaws and/or the Master Deed is of a continuing nature, in which case, the Board may levy a fine for each time period (e.g., 24 hours, 7 days, etc.) during which the violation continues. All fines duly assessed may be collected in the manner provided in Article II of these Bylaws as if the same were assessments adopted pursuant to Article II above.

ARTICLE VII

MORTGAGES

1. Notice to Association. Any Co-owner who mortgages the Co-owner's Unit shall notify the Association of the name and address of the mortgagee and the Association shall maintain such information in a book entitled "Mortgages of Units". The Association may, at the written request of a mortgagee of any such Unit, report any unpaid assessments due from the Co-owner of such Unit. The Association shall give to the holder of any first mortgage covering any Unit in the Condominium written notification of any default in the performance of the obligations of the Co-owner of such Unit that is not cured within 60 days.

2. Insurance. The Association shall notify each mortgagee appearing in said book of each company insuring the Condominium against fire, perils covered by extended coverage and vandalism and malicious mischief and the amounts of such coverage.

3. Notification of Meetings. Upon request submitted to the Association, any institutional holder of a first mortgage lien on any Unit in the Condominium shall be entitled to receive written notification of every meeting of the members of the Association and to designate a representative to attend such meeting.

ARTICLE VIII

VOTING

1. Vote. Except as limited in these Bylaws, each Co-owner shall be entitled to one vote for each Condominium Unit owned when voting by number and one vote, the value of which shall equal the percentage of value percentage allocated to the Units owned by such Co-owner as set forth in the Master Deed, when voting by value. Voting shall be by value unless otherwise expressly required by the Condominium Documents or by law. In the case of any Unit owned jointly by more than one Co-owner, the voting right appurtenant to that Unit may be exercised jointly as a single vote or may be split if all the joint Co-owners of the Unit so agree in writing.

2. Eligibility to Vote. No Co-owner, other than the Developer, shall be entitled to vote at any meeting of the Association until the Co-owner has presented evidence of ownership of a Unit in the Condominium to the Association. Except as provided in Article XI, Section 2 of these Bylaws, no Co-owner, other than the Developer, shall be entitled to vote prior to the date of the First Annual Meeting of members held in accordance with Section 2 of Article IX. The vote of each Co-owner may be cast only by the individual representative designated by such Co-owner in the notice required in Section 3 of this Article VIII or by a proxy given by such individual representative (except with respect to a vote taken pursuant to Article III, Section 5 of these Bylaws, for which proxy voting shall not be permitted).

3. Designation of Voting Representative. Each Co-owner shall file a written notice with the Association designating the individual representative who shall vote at meetings of the Association and receive all notices and other communications from the Association on behalf of such Co-owner. Such notice shall state the name and address of the individual representative designated, the number or numbers of the Condominium Unit or Units owned by the Co-owner, and the name and address of each person, firm, corporation, partnership, association, trust or other entity who is the Co-owner. Such notice shall be signed and dated by the Co-owner. The individual representative designated may be changed by the Co-owner at any time by filing a new notice in the manner herein provided. At any meeting the filing of such written notice as a prerequisite to voting may be waived by the chairman of the meeting.

4. Annual Meeting. There shall be in annual meeting of the Co-owners commencing with the First Annual Meeting held as provided in Article IX, Section 2 hereof. Other meetings shall be held as provided for in Article IX hereof. Notice of the time, place and subject matter of all meetings shall be given by mailing the same to each individual representative designated by the respective Co-owners.

5. Quorum. The presence in person or by proxy of more than one-half (1/2) in value of the Co-owners qualified to vote shall constitute a quorum for holding a meeting of the members of the Association, except for voting on questions specifically required by the Condominium Documents to require a greater quorum. The written vote of any person furnished at or prior to any duly called meeting at which meeting such person is not otherwise present in person or by proxy shall be counted in determining the presence of a quorum with respect to the question upon which the vote is cast.

6. Voting. Votes may be cast only in person or by a writing duly signed by the designated voting representative not present at a given meeting in person or by proxy. Proxies and any written votes must be filed with the Secretary of the Association at or before the appointed time of each meeting of the members of the Association. Notwithstanding the foregoing, proxy voting shall not be permitted with respect to votes taken pursuant to Article III, Section 5 of these Bylaws. Cumulative voting shall not be permitted.

7. Majority. Unless otherwise required by law or by the Condominium Documents, any action which could be authorized at a meeting of the members shall be authorized by an affirmative vote of more than fifty (50%) percent in value. The foregoing statement and any other provision of the Master Deed, these Bylaws requiring the approval of a majority (or other stated percentage) of the members shall be construed to mean, unless otherwise specifically stated, majority (or other stated percentage) in value of the votes cast by those qualified to vote and present in person or by proxy (or written vote, if applicable) at a given meeting of the Co-owners duly called and held.

ARTICLE IX

MEETINGS

1. Place of Meeting. Meetings of the Association shall be held at the principal office of the Association or at such other suitable place convenient to the Co-owners as may be designated by the Board of Directors. Meetings of the Association shall be conducted in accordance with Roberts Rules of Order or some other generally recognized manual of parliamentary procedure, when not otherwise in conflict with the Condominium Documents or the laws of the State of Michigan.

2. First Annual Meeting. The First Annual Meeting of members of the Association may be convened only by the Developer. The First Annual Meeting may be called at any time in the Developer's discretion after the first conveyance of legal or equitable title of a Unit in the Condominium to a non-developer Co-owner. As provided in Article XI, Section 2 hereof, the First Annual Meeting shall be held on or before 120 days after the conveyance of

legal or equitable title to non-developer Co-owners of seventy-five (75%) in number of the Units that may be created in the Condominium or 54 months after the first conveyance of legal or equitable title to a non-developer Co-owner of a Unit in the Condominium, whichever first occurs. The Developer may call meetings of members for informative or other appropriate purposes prior to the First Annual Meeting of members and no such meeting shall be construed as the First Annual Meeting of members. The date, time and place of such meeting shall be set by the Board of Directors, and at least 10 days' written notice thereof shall be given to each Co-owner.

3. Annual Meetings. Annual meetings of members of the Association shall be held on the third Tuesday of March each succeeding year (commencing the third Tuesday of March of the calendar year following the year in which the First Annual Meeting is held) at such time and place as shall be determined by the Board of Directors. At such meetings there shall be elected by ballot of the Co-owners a Board of Directors in accordance with the requirements of these Bylaws. The Co-owners may also transact at annual meetings such other business of the Association as may properly come before them.

4. Special Meetings. It shall be the duty of the President to call a special meeting of the Co-owners as directed by resolution of the Board of Directors or upon a petition signed by one-third (1/3) of the Co-owners presented to the Secretary of the Association, but only after the First Annual Meeting has been held. Notice of any special meeting shall state the time and place of such meeting and the purposes thereof. No business shall be transacted at a special meeting except as stated in the notice.

5. Notice of Meetings. It shall be the duty of the Secretary (or other Association officer in the Secretary's absence) to serve a notice of each annual or special meeting, stating the purpose thereof as well as the time and place where it is to be held, upon each Co-owner of record, at least 10 days but not more than 60 days prior to such meeting. The mailing, postage prepaid, of a notice to the representative of each Co-owner at the address shown in the notice required by Article VIII, Section 3 of these Bylaws to be filed with the Association shall be deemed notice served. Any member may, by written waiver of notice signed by such member, waive such notice, and such waiver, when filed in the records of the Association, shall be deemed due notice.

6. Adjournment. If any meeting of Co-owners cannot be held because a quorum is not in attendance, the Co-owners who are present may adjourn the meeting to a time not less than 10 days from the time the original meeting was called and notice of the meeting shall be provided as set forth in Section 5 of this Article IX.

7. Order of Business. The order of business at all meetings of the members shall be as follows: (a) roll call to determine the voting power represented at the meeting; (b) determination of whether quorum is present; (c) proof of notice of meeting or waiver of notice; (d) reading of minutes of preceding meeting; (e) reports of officers; (f) reports of committees; (g) appointment of inspectors of election (at annual meetings or special meetings held for the purpose of electing Directors or officers); (h) election of Directors (at annual meeting or special meetings held for such purpose); (i) unfinished business; and (j) new business. Meetings of members shall be chaired by the most senior officer of the Association present at such meeting. For purposes of this Section, the order of seniority of officers shall be President, Vice President, Secretary and Treasurer.

8. Action Without Meeting. Any action which may be taken at a meeting of the members (except for the election or removal of Directors or the commencement of litigation in accordance with Article III of these Bylaws) may be taken without a meeting by written ballot of the members. Ballots shall be solicited in the same manner as provided in Section 5 of this Article IX for the giving of notice of meetings of members. Such solicitations shall specify: (a) the number of responses needed to meet the quorum requirements; (b) the percentage of approvals necessary to approve the action; and (c) the time by which ballots must be received in order to be counted. The form of written ballot shall afford an opportunity to specify a choice between approval and disapproval of each matter and shall provide that, where the member specifies a choice, the vote shall be cast in accordance therewith. Approval by written ballot shall be constituted by receipt, within the time period specified in the solicitation, of: (i) a number of ballots which equals or exceeds the quorum which would be required if the action were taken at a meeting; and (ii) a number of votes or total percentage of approvals which equals or exceeds the

number of votes or percentage of approvals which would be required for approval if the action were taken at a meeting at which the total number of votes cast was the same as the total number of ballots cast.

9. Minutes: Presumption of Notice. Minutes or a similar record of the proceedings of meetings of members, when signed by the President or Secretary, shall be presumed truthfully to evidence the matters set forth therein. A recitation in the minutes of any such meeting that notice of the meeting was properly given shall be prima facie evidence that such notice was given.

ARTICLE X

ADVISORY COMMITTEE

An advisory committee of non-developer Co-owners shall be established either 120 days after conveyance of legal or equitable title to non-developer Co-owners of one-third of the Units that may be created, or one year after the initial conveyance of legal or equitable title to a non-developer Co-owner of a Unit in the Condominium, whichever occurs first. The advisory committee shall meet with the Board of Directors for the purpose of facilitating communication and aiding the transition of control to the association of Co-owners. The advisory committee shall cease to exist when a majority of the Board of Directors of the Association is elected by the non-developer Co-owners.

ARTICLE XI

BOARD OF DIRECTORS

1. Number and Qualification of Directors. The Board of Directors shall consist of three members, all of whom must be members of the Association or officers, partners, trustees, employees or agents of members of the Association, except for the first Board of Directors. Directors shall serve without compensation. After the First Annual Meeting, the number of directors may be increased or decreased by action of the Board of Directors, provided that the Board of Directors shall be comprised of at least five members.

2. Election of Directors.

(a) First Board of Directors. The first Board of Directors, or its successors as selected by the Developer, shall manage the affairs of the Association until the appointment of the first non-developer Co-owners to the Board. Elections for non-developer Co-owner directors shall be held as provided in subsections (b) and (c) below.

(b) Appointment of Non-developer Co-owners to Board Prior to First Annual Meeting. Not later than 120 days after conveyance of legal or equitable title to non-developer Co-owners of twenty-five (25%) percent of the Units, that may be created at least one director and not less than twenty-five (25%) percent of the Board of Directors shall be elected by non-developer Co-owners. Not later than 120 days after conveyance of legal or equitable title to non-developer Co-owners of fifty (50%) percent of the Units that may be created not less than thirty-three and one-third (33 1/3%) percent of the Board of Directors shall be elected by non-developer Co-owners. When the required percentage of conveyances has been reached, the Developer shall notify the non-developer Co-owners and request that they hold a meeting and elect the required director. Upon certification by the Co-owners to the Developer of the director so elected, the Developer shall then immediately appoint such director to the Board to serve until the First annual Meeting of members unless the director is removed pursuant to Section 7 of this Article

XI or the director resigns or becomes incapacitated.

(c) Election of Directors at and After First Annual Meeting.

(i) Subject to the terms of Article IX above, not later than 120 days after conveyance of legal or equitable title to non-developer Co-owners of seventy-five (75%) percent of the Units that may be created, and before conveyance of ninety (90%) percent of such Units, the First Annual Meeting shall be called and the non-developer Co-owners shall elect all directors on the Board of Directors, except that Developer shall have the right to designate at least one director as long as Developer owns and offers for sale at least ten (10%) percent of the Units in the Condominium or as long as ten (10%) percent of the Units remain that may be created.

(ii) Notwithstanding the formula provided in subsection (i), 54 months after the first conveyance of legal or equitable title to a non-developer Co-owner of a Unit in the Condominium, if title to at least seventy-five (75%) percent of the Units that may be created has not been conveyed to non-developer Co-owners, the First Annual Meeting shall be called and the non-developer Co-owners shall have the right to elect as provided in the Condominium Documents, a number of members of the Board of Directors equal to the percentage of Units they hold, and Developer has the right to elect, as provided in the Condominium Documents, a number of members of the Board equal to the percentage of Units which are owned by the Developer and for which all assessments are payable by Developer. This election may increase, but shall not reduce, the minimum election and designation rights otherwise established in subsection (i). Application of this subsection does not require a change in the size of the board as determined in the Condominium Documents.

(iii) If the calculation of the percentage of members of the Board of Directors that the non-developer Co-owners have the right to elect under this Section 2 or if the product of the number of members of the Board of Directors multiplied by the percentage of Units held by the non-developer Co-owners under this Section 2 results in a right of non-developer Co-owners to elect a fractional number of members of the Board of Directors, then a fractional election right of 0.5 or greater shall be rounded up to the nearest whole number, which number shall be the number of members of the Board of Directors that the non-developer Co-owners have the right to elect. After application of this formula the Developer shall have the right to elect the remaining members of the Board of Directors. Application of this subsection shall not eliminate the right of Developer to designate one director as provided in subsection (i) of this Section 2(c).

(iv) At the First Annual Meeting one-half of the directors (rounded up if fractional) shall be elected for a term of two years and the remaining directors shall be elected for a term of one year. At such meeting, all nominees shall stand for election as one slate and the number of persons equal to one-half of the number of directors (rounded up if fractional) who receive the highest number of votes shall be elected for terms of two years and the number of persons equal to the remaining directors to be elected who receive the next highest number of votes shall be elected for terms of one year. After the First Annual Meeting, the term of office (except for directors elected at the First Annual Meeting for one year terms) of each director shall be two years. The directors shall hold office until their successors have been elected and hold their first meeting.

(v) Once the Co-owners have acquired the right hereunder to elect a majority of the Board of Directors, annual meetings of Co-owners to elect directors and conduct other business shall be held in accordance with the provisions of Article IX, Section 3 hereof.

(vi) As used in this section, the term "Units that may be created" means the maximum number of Units which may be included in the Condominium in accordance with any limitation stated in the Master Deed or imposed by law.

3. Powers and Duties. The Board of Directors shall have the powers and duties necessary for the administration of the affairs of the Association and may do all acts and things necessary thereto subject always to the Condominium Documents and applicable laws.

4. Other Duties. In addition to the foregoing duties imposed by these Bylaws or any further duties which may be imposed by resolution of the members of the Association, the Board of Directors shall be responsible specifically for the following:

(a) To manage and administer the affairs of and to maintain the Condominium and the Common Elements thereof.

(b) To levy and collect assessments against and from the members of the Association and to use the proceeds thereof for the purposes of the Association.

(c) To carry insurance and collect and allocate the proceeds thereof.

(d) To rebuild improvements after casualty.

(e) To contract for and employ persons, firms, corporations or other agents to assist in the management, operation, maintenance and administration of the Condominium.

(f) To own, maintain, improve, operate and manage and to buy, sell, convey, assign, mortgage or lease (as landlord or tenant) any real or personal property (including any Unit in the Condominium and easements, rights-of-way and licenses) on behalf of the Association in furtherance of any of the purposes of the Association.

(g) To borrow money and issue evidences of indebtedness in furtherance of any or all of the purposes of the Association, and to secure the same by mortgage, pledge or other lien on property owned by the Association.

(h) To make rules and regulations in accordance with Article VI, Section 10 of these Bylaws.

(i) To establish such committees as it deems necessary, convenient or desirable and to appoint persons thereto for the purpose of implementing the administration of the Condominium and to delegate to such committees any functions or responsibilities which are not by law or the Condominium Documents required to be performed by the Board.

(j) To enforce the provisions of the Condominium Documents.

5. Management Agent. The Board of Directors may employ for the Association a professional management agent (which may include the Developer or any person or entity related thereto) at reasonable compensation established by the Board to perform such duties and services as the Board shall authorize, including, but not limited to, the duties listed in Sections 3 and 4 of this Article, and the Board may delegate to such management agent any other duties or powers which are not by law or by the Condominium Documents required to be performed by or have the approval of the Board of Directors or the members of the Association. In no event shall the Board be authorized to enter into any contract with a professional management agent, or any other contract providing for services by the Developer, in which the maximum term is greater than 3 years or which is not terminable by the association upon 90 days' written notice thereof to the other party and no such contract shall violate the provisions of Section 55 of the Act.

6. Vacancies. Vacancies in the Board of Directors which occur after the Transitional Control Date caused by any reason other than the removal of a director by a vote of the members of the association shall be filled by vote of the majority of the remaining directors, even though they may constitute less than a quorum, except that the Developer shall be solely entitled to fill the vacancy of any director whom it is permitted in the first instance to designate. Each person so elected shall be a director until a successor is elected at the next annual meeting of the members of the Association. Vacancies among non-developer Co-owner elected directors which occur prior to the

Transitional Control Date shall be filled only through election by non-developer Co-owners in the manner specified in Section 2(b) of this Article.

7. Removal. At any regular or special meeting of the Association duly called with due notice of the removal action proposed to be taken, any one or more of the directors may be removed with or without cause by the affirmative vote of more than fifty (50%) percent in number and in value of all of the Co-owners and a successor may then and there be elected to fill any vacancy thus created. The quorum requirement for the purpose of filling such vacancy shall be the normal quorum set forth in Article VIII, Section 5. Any director whose removal has been proposed by the Co-owners shall be given an opportunity to be heard at the meeting. Developer may remove and replace any or all of the directors selected by it at any time or from time to time in its sole discretion. Likewise, any director selected by the non-developer Co-owners to serve before the First Annual Meeting may be removed before the First Annual Meeting in the same manner set forth in this paragraph for removal of directors generally.

8. First Meeting. The first meeting of a newly elected Board of Directors shall be held within 30 days of election at such place as shall be fixed by the directors at the meeting at which such directors were elected and no notice shall be necessary to the newly elected directors in order legally to constitute such meeting, providing a majority of the whole Board shall be present.

9. Regular Meetings. Regular meetings of the Board of Directors may be held at such times and places as shall be determined from time to time by a majority of the directors, but at least two such meetings shall be held during each fiscal year. Notice of regular meetings of the Board of Directors shall be given to each director personally, by mail, telephone, facsimile or telegraph, at least 10 days prior to the date named for such meeting.

10. Special Meetings. Special meetings of the Board of Directors may be called by the President on three days' notice to each director given personally, by mail, telephone, facsimile or telegraph, which notice shall state the time, place and purpose of the meeting. Special meetings of the Board of Directors shall be called by the President or Secretary in like manner and on like notice on the written request of two directors.

11. Waiver of Notice. Before or at any meeting of the Board of Directors, any director may, in writing, waive notice of such meeting and such waiver shall be deemed equivalent to the giving of such notice. Attendance by a director at any meetings of the Board shall be deemed a waiver of notice by him of the time and place thereof. If all the directors are present at any meeting of the Board, no notice shall be required and any business may be transacted at such meeting.

12. Quorum. At all meetings of the Board of Directors, a majority of the directors shall constitute a quorum for the transaction of business and the acts of the majority of the directors present at a meeting at which a quorum is present shall be the acts of the Board of Directors. If, at any meeting of the Board of Directors, there is less than a quorum present, the majority of those present may adjourn the meeting to a subsequent time upon 24 hours' prior written notice delivered to all directors not present. At any such adjourned meeting, any business which might have been transacted at the meeting as originally called may be transacted without further notice. The joinder of a director in the action of a meeting by signing and concurring in the minutes thereof shall constitute the presence of such director for purposes of determining a quorum.

13. First Board of Directors. All of the actions (including, without limitation, the adoption of these Bylaws and any Rules and Regulations for the association, and any undertaking or contracts entered into with others on behalf of the Association) of the first Board of Directors of the Association named in its articles of incorporation or any successors thereto appointed before the First Annual Meeting of Co-owners shall be binding upon the Association in the same manner as though such actions had been authorized by a Board of Directors duly elected by the Co-owners.

14. Fidelity Bonds. The Board of Directors shall require that all officers and employees of the Association handling or responsible for Association funds shall furnish adequate fidelity bonds. The premiums on such bonds shall be expenses of administration.

ARTICLE XII

OFFICERS

1. Officers. The principal officers of the Association shall be a President, who shall be a member of the Board of Directors, a Vice President, a Secretary and a Treasurer. The directors may appoint an Assistant Treasurer, and an Assistant Secretary, and such other officers as in their judgment may be necessary. Any two offices except that of President and Vice President may be held by one person.

(a) President. The President shall be the chief executive officer of the Association, and shall preside at all meetings of the Association and of the Board of Directors. The President shall have all of the general powers and duties which are usually vested in the office of the president of an association, including, but not limited to, the power to appoint committees from among the members of the Association from time to time in the President's discretion as may be deemed appropriate to assist in the conduct of the affairs of the Association.

(b) Vice President. The Vice President shall take the place of the President and perform the President's duties whenever the President shall be absent or unable to act. If neither the President nor the Vice President is able to act, the Board of Directors shall appoint some other member of the Board to so do on an interim basis. The Vice President shall also perform such other duties as shall from time to time be imposed by the Board of Directors.

(c) Secretary. The Secretary shall keep the minutes of all meetings of the Board of Directors and the minutes of all meetings of the members of the Association and shall have charge of the corporate seal and of such books and papers as the Board of Directors may direct; and shall, in general, perform all duties incident to the office of the Secretary.

(d) Treasurer. The Treasurer shall have responsibility for the Association's funds and securities and shall be responsible for keeping full and accurate accounts of all receipts and disbursements in books belonging to the Association. The Treasurer shall be responsible for the deposit of all monies and other valuable effects in the name and to the credit of the Association, and in such depositories as may, from time to time, be designated by the Board of Directors.

BONDED ?

2. Election. The officers of the Association shall be elected annually by the Board of Directors at the organizational meeting of each new Board and shall hold office at the pleasure of the Board.

3. Removal. Upon affirmative vote of a majority of the members of the Board of Directors, any officer may be removed either with or without cause, and the officer's successor elected at any regular meeting of the Board of Directors or at any special meeting of the Board called for such purpose. No such removal action may be taken, however, unless the matter shall have been included in the notice of such meeting. The officer who is proposed to be removed shall be given an opportunity to be heard at the meeting.

4. Duties. The officers shall have such other duties, powers and responsibilities as shall, from time to time, be authorized by the Board of Directors.

ARTICLE XIII

SEAL

The Board of Directors may adopt a seal on behalf of the Association which shall have inscribed thereon the name of the Association, the words "corporate seal" and "Michigan".

DET_C\371937.4

RIVER PARK VILLAGE CONDOMINIUM

A CONDOMINIUM SUBDIVISION BEING PART OF THE SOUTHEAST 1/4 OF SECTION 34, TOWN 1 NORTH, RANGE 8 EAST OF SECTION 34, TOWN 1 NORTH, RANGE 8 EAST CITY OF NORTHVILLE (FORMERLY NOVI TOWNSHIP), OAKLAND COUNTY, MICHIGAN

OAKLAND COUNTY CONDOMINIUM SUBDIVISION PLAN NO. 1332

ATTENTION COUNTY REGISTER OF DEEDS
The condominium subdivision plan number must be assigned in consecutive sequence. When a number has been assigned to this project, it must be properly shown in the title on this sheet and in the Surveyor's Certificate on sheet Number 2.

LEGAL DESCRIPTION

Part of the Southeast 1/4 of Section 34, Town 1 North, Range 8 East, City of Northville (formerly Novi Township), Oakland County, Michigan, South 33 feet of said Section 34, thence West, along the South line of Section 34 and the center line of Base Line Road, 518.76 feet; thence North 15° 53' 37" East, along the Easterly line of the Oak Road right-of-way (formerly the Pere Marquette Railroad), 222.77 feet, (recorded as about 223 feet); to the Southeast corner of the Middle Rouge River; concrete pier of a railroad bridge over the Middle Rouge River, parallel with the South line of Section 34, 458.24 feet; thence South 00° 08' 21" East, along the East line of Section 34 and the centerline of Old Novi Road (66 feet wide), 214.25 feet to the Pier of the Middle Rouge River; thence North 15° 53' 37" East, along the Easterly line of the Oak Road right-of-way, 222.77 feet. Subject to the rights of the public over the South 33 feet for Base Line Road and the East 33 feet for Old Novi Road. Subject to easements and/or encumbrances of record.

INDEX OF DRAWINGS

- 1...COVER SHEET
- 2...SURVEY PLAN
- 3...SITE PLAN
- 4...UTILITY PLAN
- 5...BUILDING DETAIL
- 6...FLOOR PLANS
- 7...FLOOR PLANS & SECTION
- 8...FLOOD PLAIN PLAN

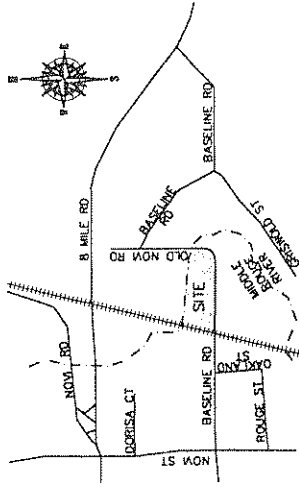

LOCATION MAP
NOT TO SCALE

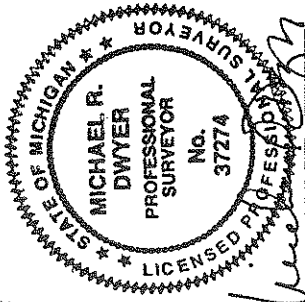

MICHAEL R. DWYER, P.S.
PROFESSIONAL SURVEYOR #37274
PRESIDENT
MCNEELY & LINCOLN ASSOCIATES, INC.

02-05-01
DATE

SURVEYOR

MCNEELY & LINCOLN ASSOCIATES, INC.
37741 PEMROKE AVE
LIVONIA, MICHIGAN 48152

DEVELOPER

RIVER PARK VILLAGE BUILDING CO., L.L.C.
32000 NORTHWESTERN HIGHWAY
SUITE 220
FARMINGTON HILLS, MICHIGAN 48334

RIVER PARK VILLAGE CONDOMINIUM COVER SHEET	
DRAWN BY: TFP	PROPOSED DATE: 02/05/01
DATE: 02/05/01	
FILE NAME: 78710601.DWG	
PROJECT NO.: 7871.06	
SCALE: NONE	
SHEET 1 OF 8	

MCNEELY & LINCOLN
ASSOCIATES, INC.
CIVIL ENGINEERING & LAND SURVEYING
PH. (734)432-9777 FAX (734)432-9786
37741 PEMROKE, LIVONIA, MICHIGAN 48152

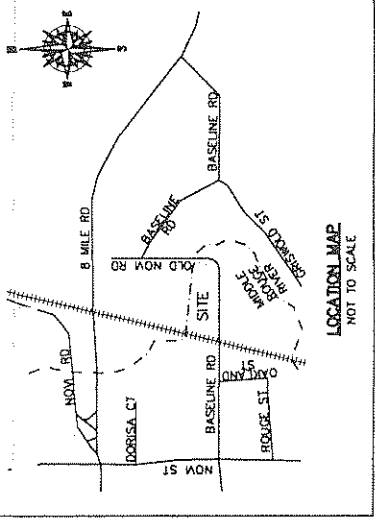

I, Michael R. Dwyer, a Professional Surveyor of the State of Michigan, hereby certify:
 That the subdivision plan known as "River Park Village Condominium Subdivision Condominium" Oakland County, Michigan, represents the true and correct location of the boundaries and encroachments upon the lands and properly described as shown;
 That the required monuments and iron markers have been located in the ground as required by rules promulgated under Act No. 59 of the Public Acts of 1978 as amended and other laws placed within one year from the date of plan recording;
 That the accuracy of this survey is within the limits required by the rules of promulgated under section 142 of Act No. 59 of the Public Acts of 1978 as amended;
 That the bearings, as shown, are noted on the survey plan as required by the rules of promulgated under section 142 of Act No. 59 of the Public Acts of 1978 as amended.

02-05-01
 DATE
 Michael R. Dwyer, P.S.
 Professional Surveyor #37274
 37741 Farmington Rd.
 Livonia, Michigan 48150

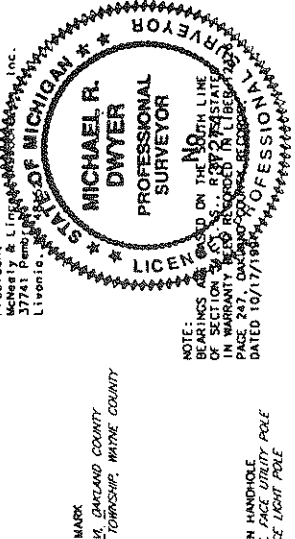

NOTES:
 BEARINGS ARE BASED ON THE NAD 83 LINE OF SECTION 34, T.15N, R.2E, STATE OF MICHIGAN IN WARRANTY DEED RECORDED IN LEBER COUNTY CLERK'S OFFICE ON 10/17/1988.
 GRAPHIC SCALE
 0 15 30 60 120
 (IN FEET)
 1 INCH = 30 FEET

PROPOSED DATED: 02/05/01
RIVER PARK VILLAGE CONDOMINIUM
 SURVEY PLAN
 DRAWN BY: JPP
 DATE: 02/05/01
 FILE NAME: 78710502.DWG
 PROJECT NO.: 7871.06
 SCALE: 1 INCH = 30 FEET
 SHEET 2 OF 8

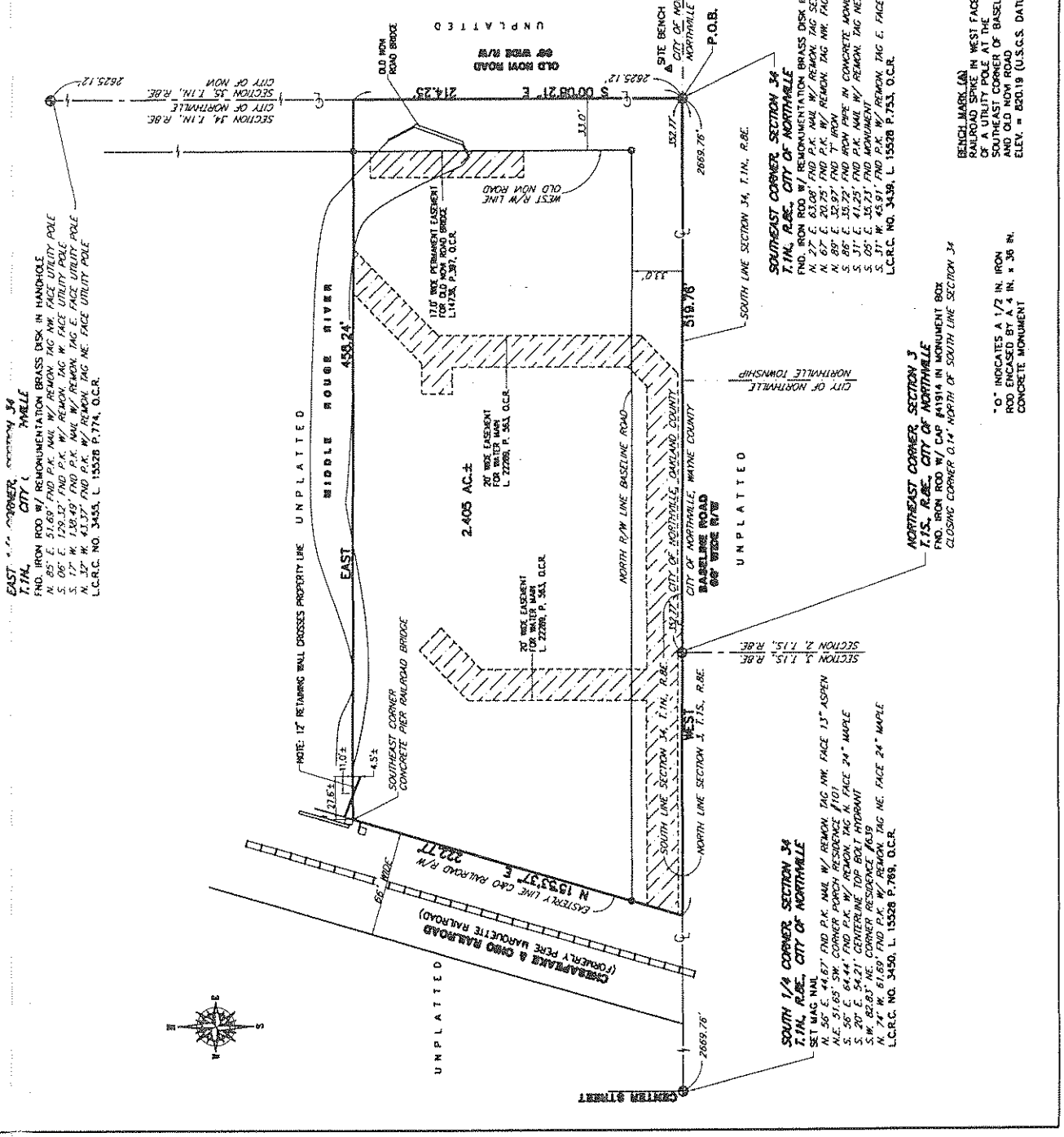

BENCH MARK (LM)
 RAILROAD SPIKE IN WEST FACE
 OF SOUTHWEST CORNER OF BASELINE RD
 AND OLD NOW ROAD
 ELEV. = 250.19 (U.S.G.S. DATUM)

O INDICATES A 1/2 IN. IRON
 ROD ENCASED BY A 1 IN. X 36 IN.
 CONCRETE MONUMENT

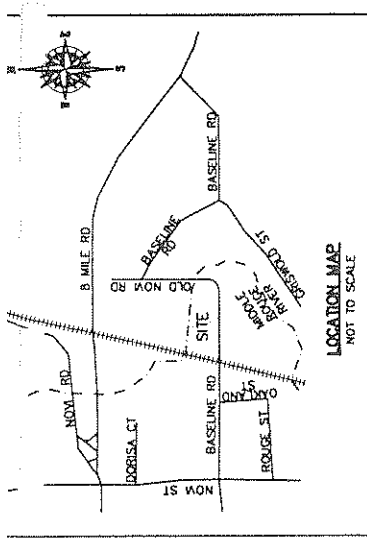

COORDINATES

No.	Easting	Northing
1	5000.00	5000.00
2	5000.00	4480.24
3	5033.00	4489.63
4	5214.25	4541.74
5	5214.25	4999.49
6	5040.25	4988.00
7	5040.25	4888.00
8	5174.05	4888.05
9	5174.05	4812.32
10	5109.73	4855.49
11	5040.25	4599.78
12	5040.25	4599.78
13	5174.25	4599.61

NOTES:

1. SEE DETAIL SHEET No. 5 FOR UNIT NUMBER DETAIL
2. ALL IMPROVEMENTS NEAR/ADJACENT TO BUILT

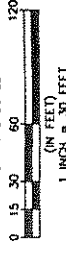
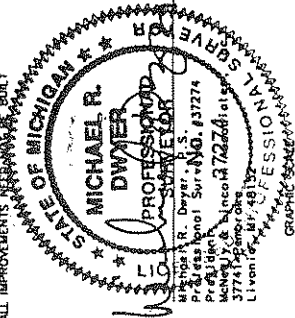

02-05-01
DATE

RIVER PARK VILLAGE CONDOMINIUM
SITE PLAN
 DRAWN BY: TPP
 DATE: 02/05/01
 FILE NAME: 78710603.DWG
 PROJECT NO.: 7871.05
 SCALE: 1 INCH = 30 FEET
 SHEET 3 OF 8
 PROPOSED DATED: 02/05/01
MCNEELY & LINCOLN
 CIVIL ENGINEERING & LAND SURVEYING
 PH: (734)432-9777
 FAX: (734)432-9786
 37741 PLOURDE, LINDA, MICHIGAN 48152

EAST 1/4 CORNER SECTION 34
T.1N., R.6E., CITY OF NORTHVILLE

NOTE: 1' REMAINING WALL CROSSES PROPERTY LINE

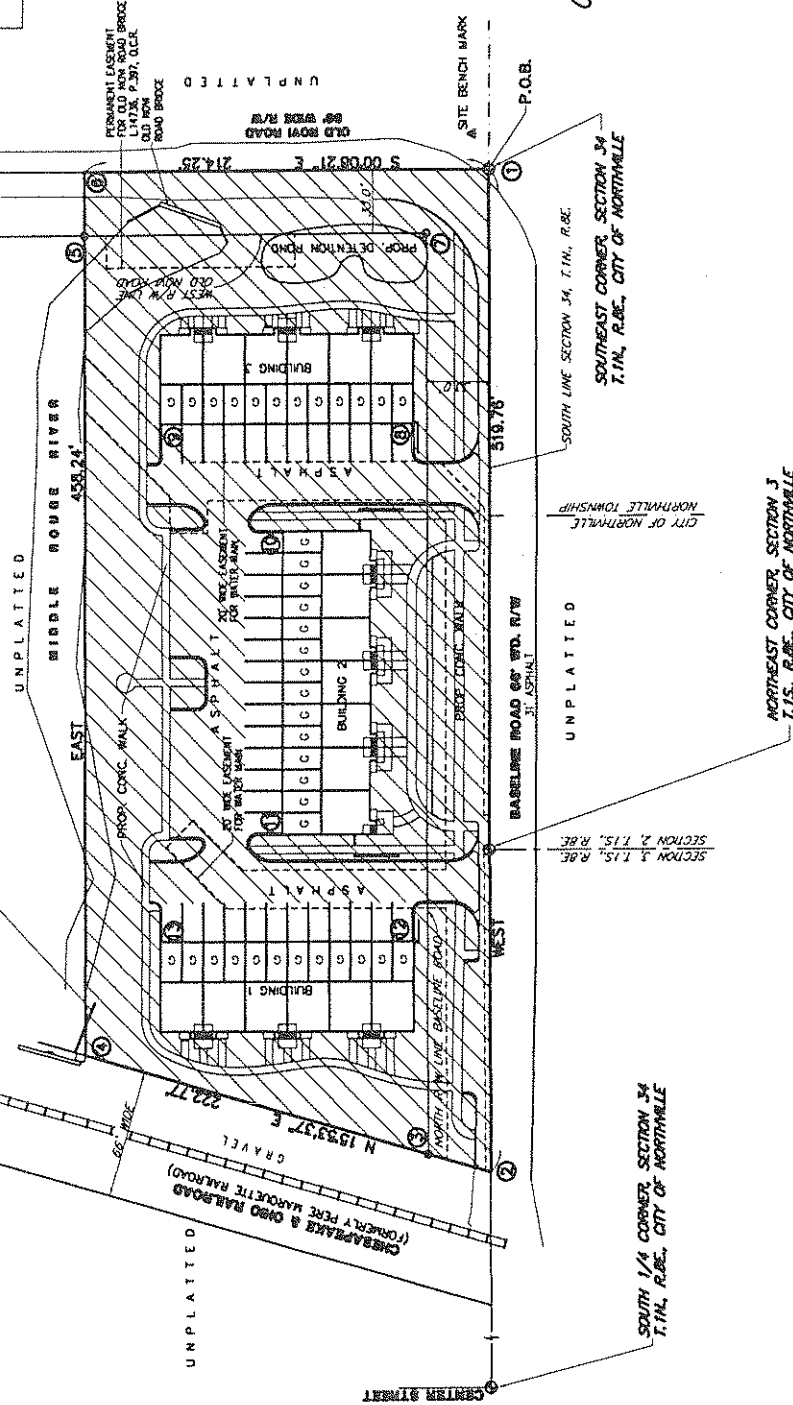

- LEGEND:**
- LIMITS OF OWNERSHIP
 - GENERAL COMMON ELEMENTS
 - COORDINATE NUMBER
 - INDICATES A 1/2 IN. IRON ROD ENCASED BY A 4 IN. x 36 IN. CONCRETE MONUMENT

BENCHMARK (A)
RAILROAD SPINE IN WEST FACE
OF A UTILITY POLE AT THE
SOUTHEAST CORNER OF BASELINE RD
AND OLD NOW ROAD
ELEV. = 800.19 (U.S.G.S. DATUM)

NORTHEAST CORNER SECTION 3
T.1S., R.6E., CITY OF NORTHVILLE

CITY OF NORTHVILLE
NORTHVILLE TOWNSHIP

SECTION 2, T.1S., R.6E.

SECTION 3, T.1S., R.6E.

SOUTH 1/4 CORNER SECTION 34
T.1N., R.6E., CITY OF NORTHVILLE

SOUTH LINE SECTION 34, T.1N., R.6E.
SOUTHEAST CORNER SECTION 34
T.1N., R.6E., CITY OF NORTHVILLE

P.O.B.

SITE BENCH MARK

PERMANENT EASEMENT
FOR OLD NOW ROAD BRIDGE
CONVEYED BY P.397, O.C.K.
ROAD BRIDGE

UNPLATTED

OLD NOW ROAD

UNPLATTED

5 0008 21' E

214.25

PROPOSED DETENTION POND

WEST R/W LINE
OLD NOW ROAD

UNPLATTED

214.25

PROPOSED ASPHALT DRIVE ASSESSMENT
FOR WATER MAIN

UNPLATTED

459.24'

MIDDLE ROUSE RIVER

UNPLATTED

EAST

PROPOSED CONC. WALK

UNPLATTED

519.78

BASELINE ROAD, 66' WID. R/W

UNPLATTED

ASPHALT

PROPOSED CONC. WALK

UNPLATTED

222.77

N 159°37' E

GRAVEL

UNPLATTED

CHESAPEAKE & OLD ROAD

UNPLATTED

(FORMERLY PORT MARQUETTE RAILROAD)

UNPLATTED

CENTRAL STREET



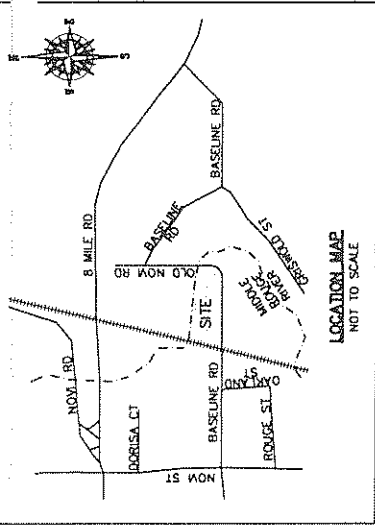

LEGEND

- SANITARY SEWER (SAN)
- WATER MAIN (W.M.)
- GAS MAIN (G.M.)
- OVER HEAD WIRES
- GATE VALVE & WELL (GV&W)
- HYDRANT (HYD)
- CATCH BASIN (C.B.)
- SANITARY MH (SMH)
- GARAGE
- INDICATES A 1/2 IN. IRON ROD ENCASED BY A 4 IN. x 36 IN. CONCRETE MONUMENT

NOTES:

- EXISTING OFF-SITE UTILITY INFORMATION FROM CITY OF NORTHVILLE AND UTILITY OWNERS.
- ON-SITE AND PROPOSED OFF-SITE UTILITY INFORMATION FROM McNEELY & LINCOLN ASSOCIATES, INC.
- GAS, ELECTRIC & COMMUNICATION CABLES WILL BE SHOWN ON THE AS-BUILT PLANS.
- UTILITY METERS WILL BE SHOWN ON THE AS-BUILT PLANS.
- ALL UTILITIES ARE PROPOSED UNLESS OTHERWISE NOTED
- ALL IMPROVEMENTS NEED NOT BE BUILT

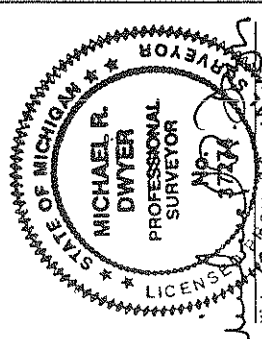

Michael R. Dwyer
Professional Surveyor
President
McNeely & Lincoln Associates, Inc.
37741 Pembroke
Livonia, MI 48152

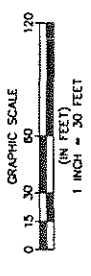

RIVER PARK VILLAGE CONDOMINIUM
UTILITY PLAN
 DRAWN BY: TJP
 DATE: 02/05/01
 FILE NAME: 78710504.DWG
 PROJECT NO.: 7871.06
 SCALE: 1 INCH = 30 FEET
 SHEET 4 OF 8

EAST 1/4 CORNER SECTION 34
T.1N., R.6E., CITY OF NORTHVILLE

NOTE: 1' RETAINING WALL CROSSES PROPERTY LINE

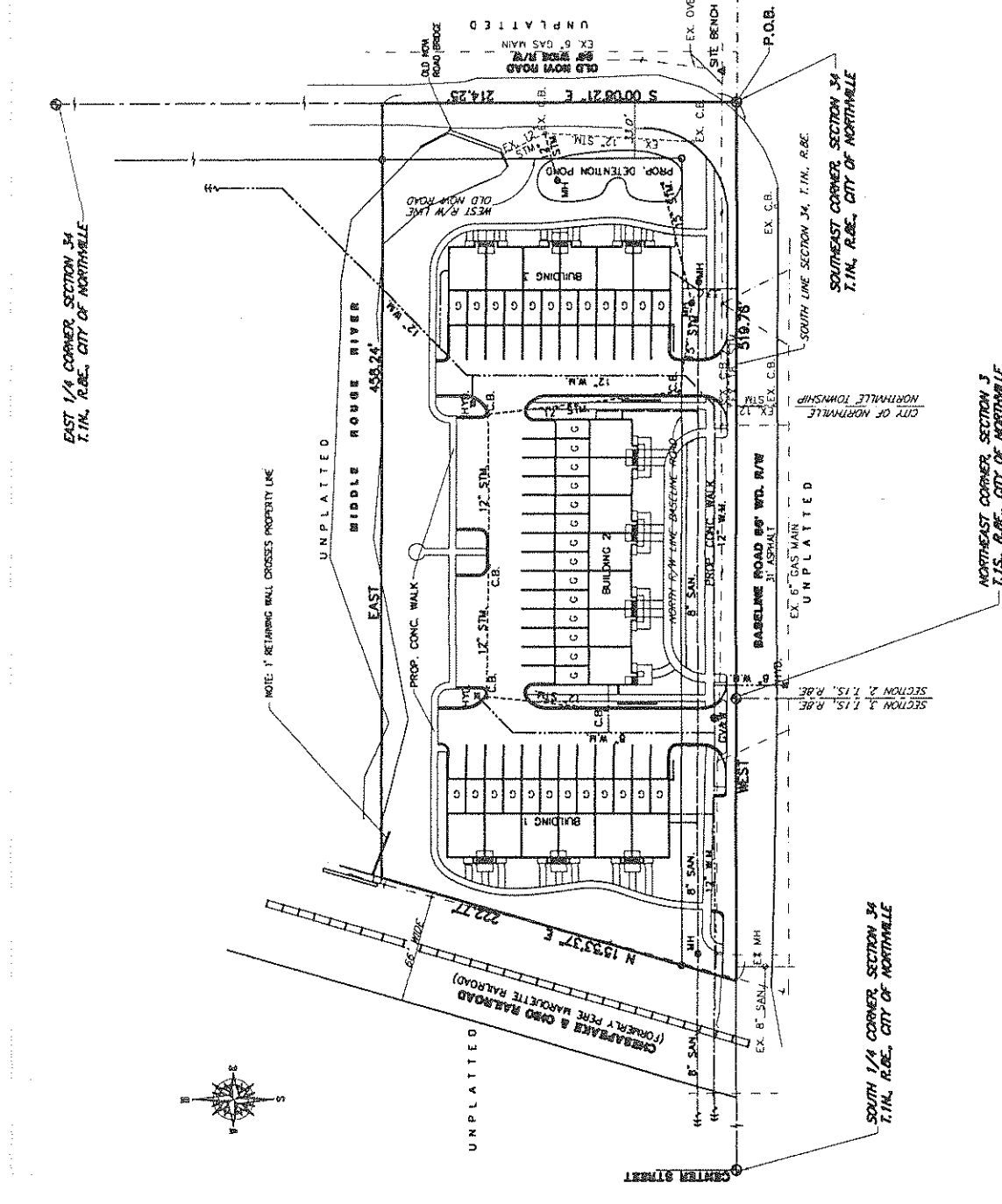

BENCHMARK (A)
RAILROAD SPIKE IN WEST FACE
OF A UTILITY POLE AT THE
SOUTH EAST CORNER OF
AND OLD NOW ROAD
ELEV. = 820.19 (U.S.G.S. DATUM)

02-05-01
DATE



SOUTH 1/4 CORNER SECTION 34
T.1N., R.6E., CITY OF NORTHVILLE

NORTHEAST CORNER SECTION 3
T.1S., R.6E., CITY OF NORTHVILLE

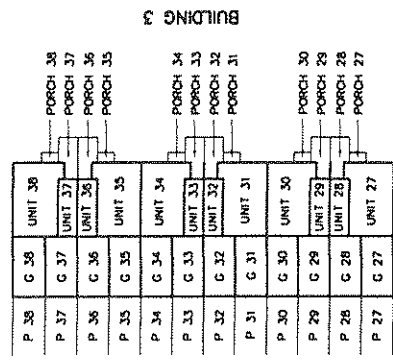
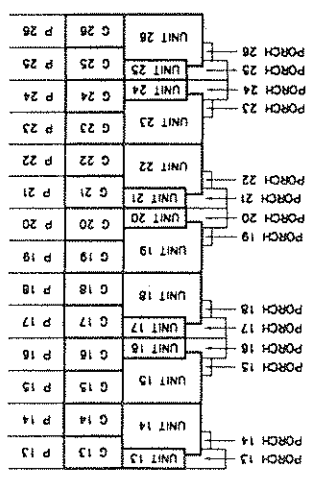
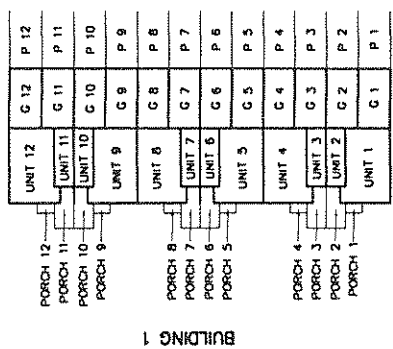
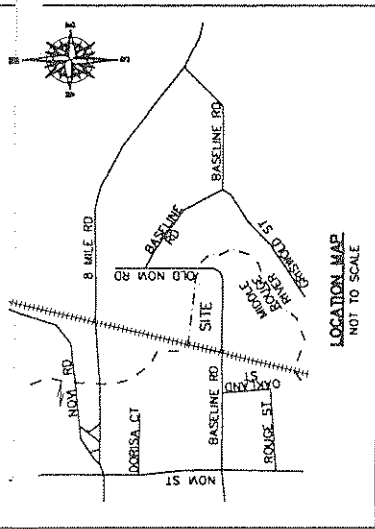

BUILDING 2

02-05-01
DATE

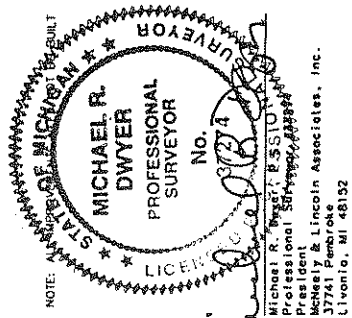

NOTE: MICHAEL R. DWYER IS A REGISTERED PROFESSIONAL SURVEYOR.
Michael R. Dwyer, P.E., S.T.S.
Professional Surveyor
Lincoln Associates, Inc.
37741 Pembroke
Livonia, MI 48152

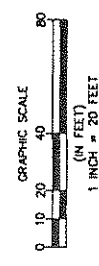

- LEGEND**
- G 00 GARAGE UNIT NUMBER (LIMITED COMMON ELEMENT)
 - P 00 PARKING UNIT NUMBER (LIMITED COMMON ELEMENT)
 - PORCH 00 PORCH UNIT NUMBER (LIMITED COMMON ELEMENT)

RIVER PARK VILLAGE CONDOMINIUM
BUILDING DETAIL
DRAWN BY: JPP
DATE: 02/05/01
FILE NAME: 7871065.DWG
PROJECT NO.: 787106
SCALE: 1 INCH = 20 FEET
SHEET 5 OF 8

PROPOSED DATED: 02/05/01

MCNEELY & LINCOLN
ASSOCIATES, INC.
CIVIL ENGINEERING & LAND SURVEYING
P.O. BOX 132-8777 FAX (734) 32-8786
37741 PEMROKE, LIVONIA, MICHIGAN 48152

UNIT NO.	UNIT TYPE	UNIT TYPE
1	B	B-R
2	B	B
3	B-R	A
4	A-R	A-R
5	A	B-R
6	B-R	A
7	B-R	A
8	A-R	A-R
9	A	B-R
10	B	B
11	B-R	A
12	A-R	B-R
13	B	B-R
14	A	B
15	A-R	A
16	B-R	A-R
17	B	B-R
18	A-R	B
19	A-R	A

R = REVERSED

TOTAL SQUARE FEET
 UNIT A = 1704.47
 UNIT B = 1684.99
 FIRST FLOOR ELEVATIONS
 UNIT A = 864.65
 UNIT B = 900.02

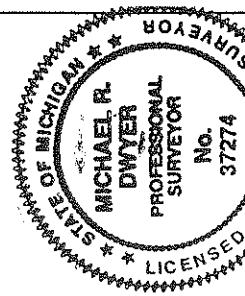

02-05-01
 DATE
 Michael R. Dwyer, P.S.
 Professional Surveyor #37274
 McNeely & Lincoln Associates, Inc.
 37741 Pembroke
 Livonia, MI 48152

RIVER PARK VILLAGE CONDOMINIUM
 FLOOR PLANS
 DRAWN BY: TRP
 DATE: 02/05/91
 FILE NAME: 78710606.DWG
 PROJECT NO.: 7871.06
 SCALE: 1 INCH = 4 FEET
 SHEET 5 OF 8

PROPOSED DATED: 02/05/91

MCNEELY & LINCOLN
 Associates, Inc.
 CIVIL ENGINEERS & SURVEYORS
 37741 Pembrooke, Livonia, Michigan 48152

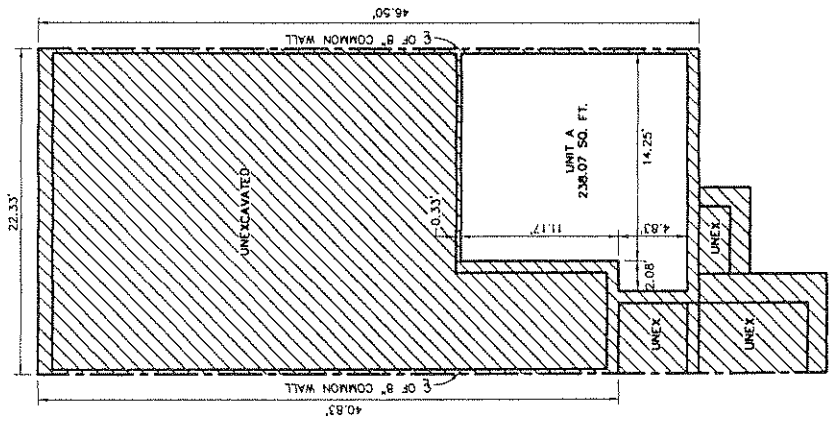
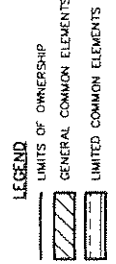
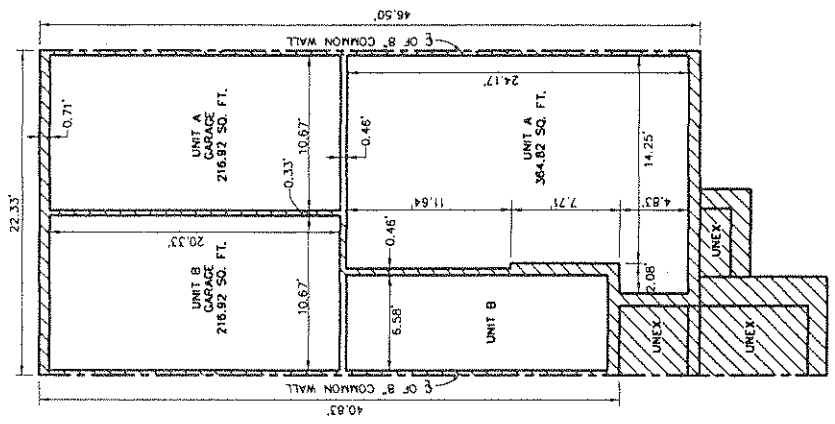
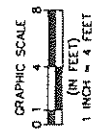
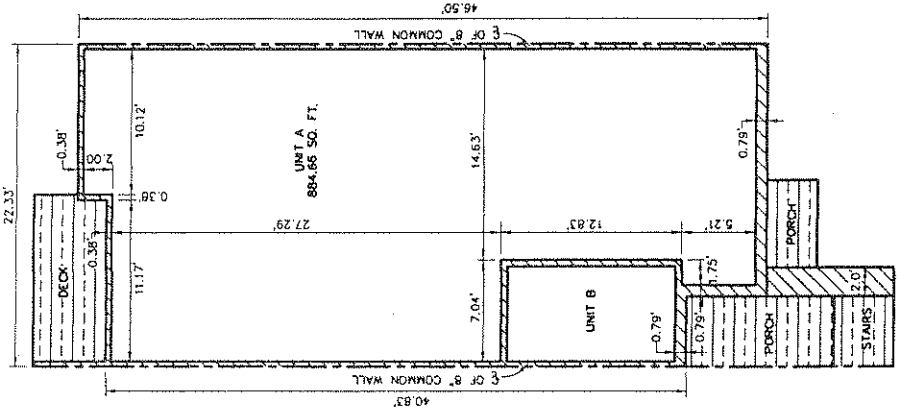

FOUNDATION PLAN
 NOTE: ALL WALLS ARE 0.83 FEET THICK UNLESS OTHERWISE NOTED

FOUNDATION PLAN
 NOTE: ALL WALLS ARE 0.83 FEET THICK UNLESS OTHERWISE NOTED

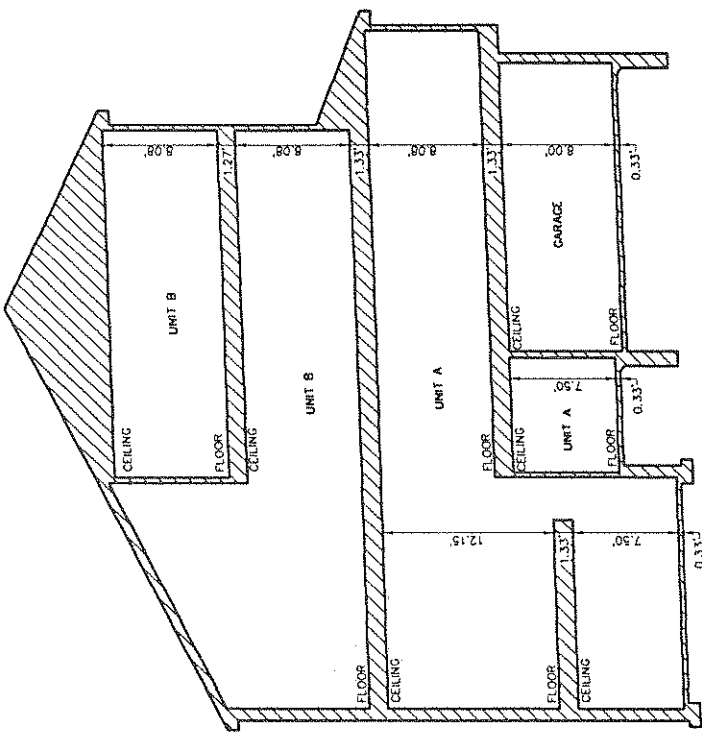

SECTION A-A

02-05-01
 DATE
 Michael R. Dwyer, P.S.
 Professional Surveyor #37274
 President
 McNeely & Lincoln Associates, Inc.
 3774 Lakeside
 Livonia, MI 48152

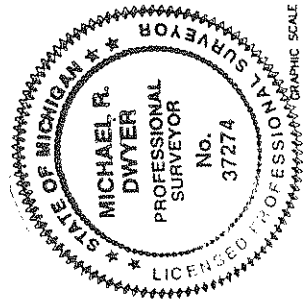

RIVER PARK VILLAGE CONDOMINIUM
 FLOOR PLANS & SECTION
 PROPOSED DATED: 02/05/01
 DRAWN BY: JPP
 DATE: 02/05/01
 FILE NAME: 78710601.DWG
 PROJECT NO.: 7871.06
 SCALE: 1 INCH = 4 FEET
 SHEET 7 OF 8

MCNEELY & LINCOLN
 Associates, Inc.
 CIVIL ENGINEERING & SURVEYING
 PH: (734)432-3777 FAX: (734)432-9786
 3774 LAKESIDE, LIVONIA, MICHIGAN 48152

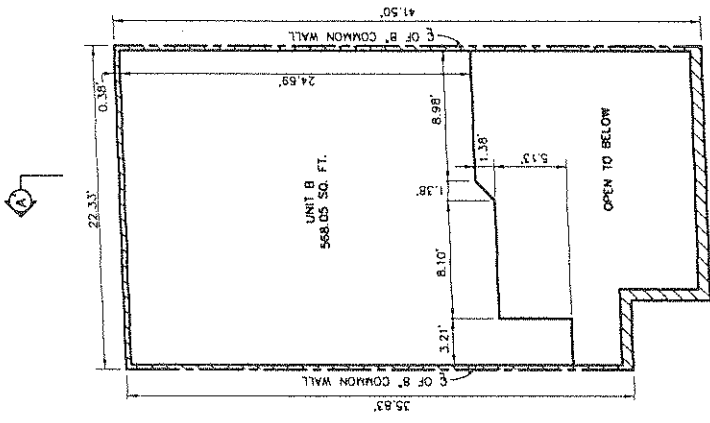

THIRD FLOOR PLAN
 NOTE: ALL WALLS ARE 0.79 FEET THICK UNLESS OTHERWISE NOTED

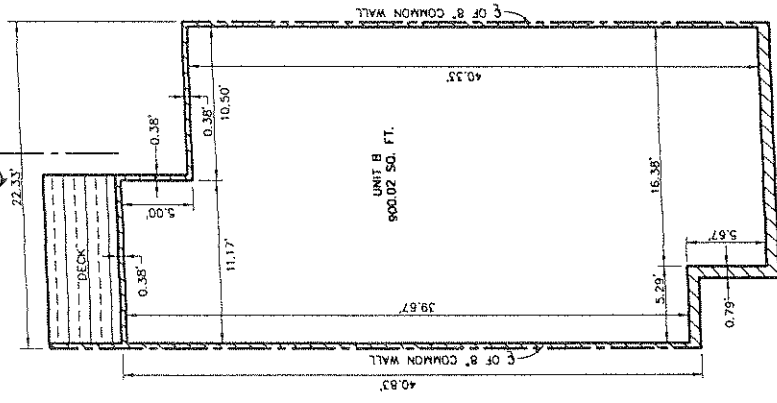
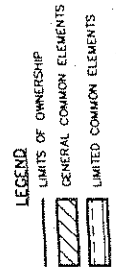

SECOND FLOOR PLAN
 NOTE: ALL WALLS ARE 0.79 FEET THICK UNLESS OTHERWISE NOTED

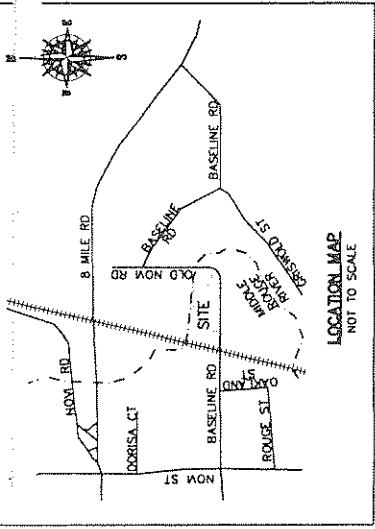

FLOOD PLAIN EXCLUSION AREA

Port of the Southeast 1/4 of Section 34, Town 1 North, Range 8 East, City of Northville (formerly Novi Township), Oakland County, Michigan, more particularly described as:

Commencing at the Southeast corner of said Section 34; thence West, along the South line of said Section 34 and the center line of Base Line Road 301.2 feet to the Point of Beginning; thence North 15° 53' 33" East, along the East line of the C&O Railroad right-of-way (formerly the Pere Marquette Railroad), 219.18 feet; thence South 69° 01' 47" East, 34.51 feet; thence South 80° 42' 52" East, 76.43 feet; thence North 78° 13' 27" East, 50.86 feet; thence South 81° 35' 15" East, 52.09 feet; thence South 86° 57' 51" East, 63.86 feet; thence North 79° 12' 14" East, 16.06 feet; thence South 71° 37' 34" East, 30.10 feet; thence North 77° 17' 25" East, 6.91 feet; thence South 34° 03' 40" East, 25.65 feet; thence South 24° 15' 36" East, 30.81 feet; thence South 38° 41' 39" East, 21.47 feet; thence South 05° 06' 40" West, 89.06 feet; thence North 89° 58' 40" West, 100.17 feet; thence South 74° 24' 00" West, 145.05 feet to the Point of Beginning. Containing 7.76 Acres, more or less. Subject to easements and/or encroachments of record.

STATE OF MICHIGAN
MICHAEL R. DWYER
 REGISTERED PROFESSIONAL SURVEYOR
 License No. 11437274
 48100 Livestock Farm Rd., P.O. Box 13727
 Livestock Farm, Livonia, Michigan 48150
 Phone: (313) 437-7400

PROFESSIONAL SURVEYOR

DATE: 02-05-01

DRAWN BY: TJP

DATE: 02/05/01

FILE NAME: 78710508.DWG

PROJECT NO.: 7871.06

SCALE: 1 INCH = 30 FEET

SHEET 8 OF 8

EAST 1/4 CORNER SECTION 34
 T.1N. R.8E. CITY OF NORTHVILLE

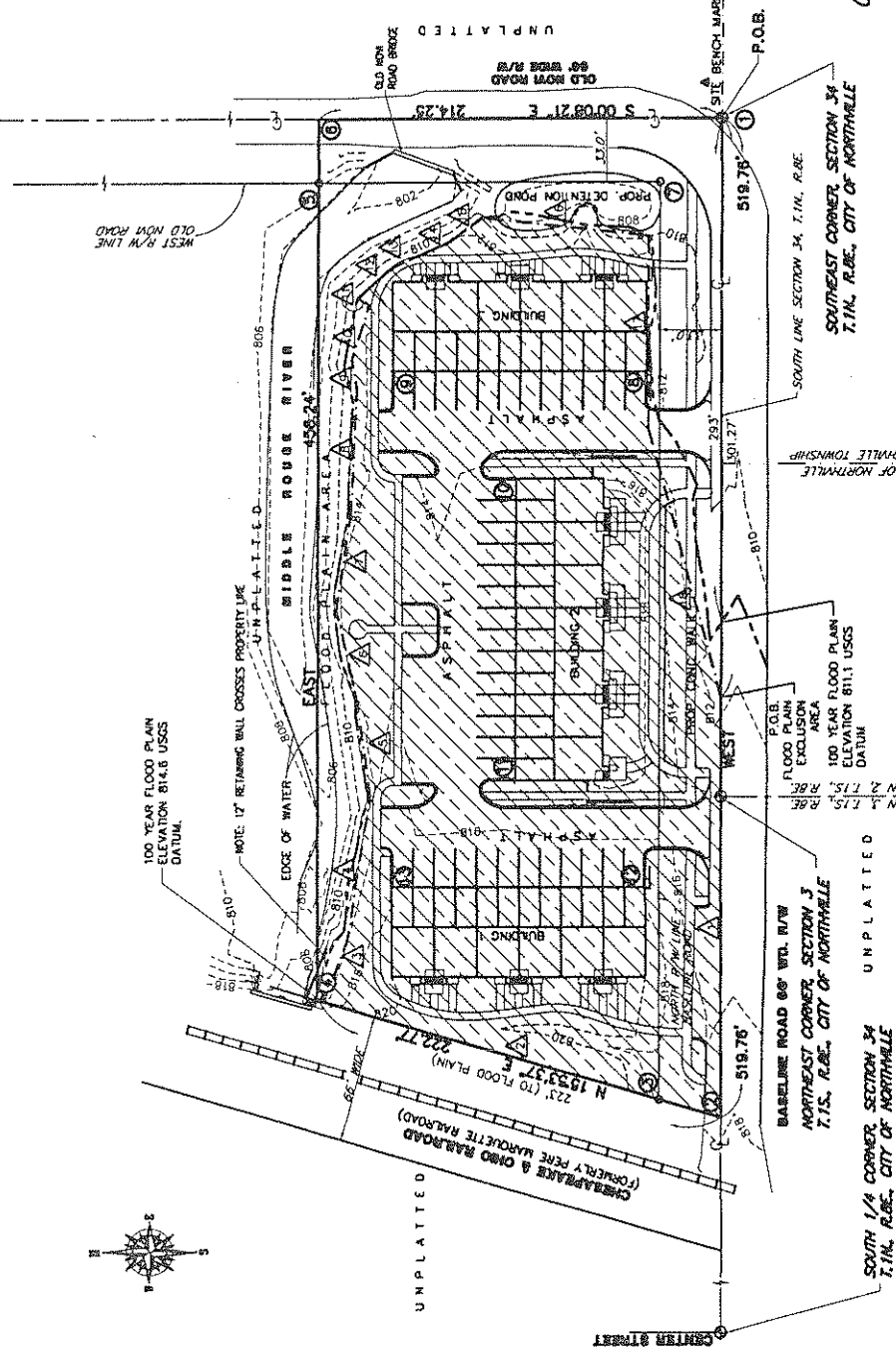

NOTES:

1. FLOOD PLAIN EXCLUSION AREA FROM FEMA LETTER OF MAP AMENDMENT DATED JULY 27, 2000, CASE NO. 00-05-3518A.

2. FLOOD PLAIN ELEVATION DATA OBTAINED FROM FEMA FLOOD INSURANCE RATE MAP, CITY OF NORTHVILLE, COMMUNITY PANEL NUMBER 260235 0001 B, REVISED DECEMBER 6, 1999.

FLOOD PLAIN EXCLUSION AREA LINE TABLE

1: WEST	5219.49	E	219.18'
2: S	80.01	E	34.51'
3: S	80.42	E	76.43'
4: S	81.35	E	50.20'
5: N	78.13	E	46.85'
6: S	81.35	E	52.09'
7: S	86.57	E	63.86'
8: S	79.12	E	16.06'
9: N	77.17	E	30.10'
10: N	21.77	E	6.91'
11: S	40.53	E	20.77'
12: S	34.05	E	5.65'
13: S	24.15	E	30.81'
14: S	38.41	E	21.47'
15: S	06.43	W	89.06'
16: S	58.40	W	100.17'
17: S	74.24	W	145.05'

COORDINATES

No.	NORTHING	EASTING
1	5000.00	5000.00
2	5000.00	4480.24
3	5033.00	4489.63
4	5214.25	4541.24
5	5214.25	4866.48
6	5033.00	4866.92
7	5040.15	4868.00
8	5174.65	4868.05
9	5109.67	4812.32
10	5109.73	4855.49
11	5040.25	4599.76
12	5174.75	4599.61

LEGEND

△ FLOOD PLAIN EXCLUSION AREA LINE TABLE NUMBER

--- LIMITS OF FLOOD PLAIN EXCLUSION AREA (ELEVATION VARIES)

--- LIMITS OF OWNERSHIP

--- FLOOD ZONE X

--- SEE NOTE 1

○ COORDINATE NUMBER

"O" INDICATES A 1/2 IN. IRON ROD ENCASED BY A 4 IN. x 36 IN. CONCRETE MONUMENT

III. ARTICLES OF INCORPORATION

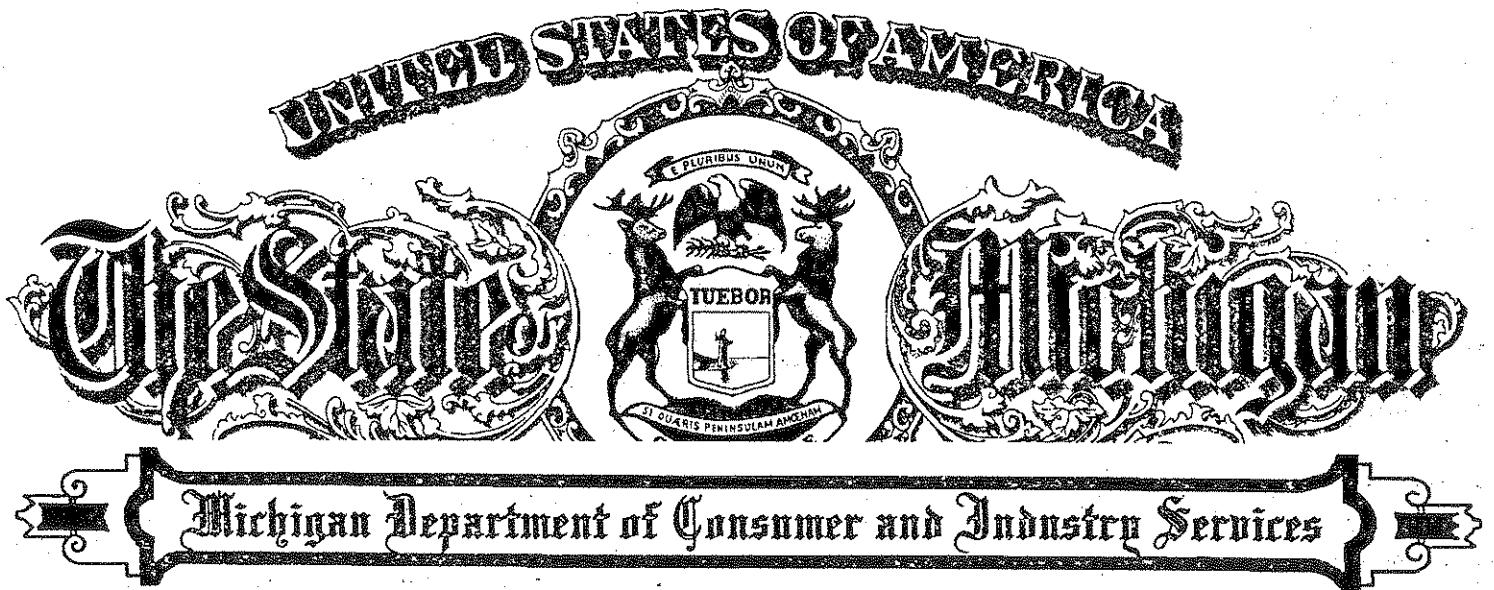

Lansing, Michigan

This is to Certify That

RIVER PARK VILLAGE CONDOMINIUM HOMEOWNERS' ASSOCIATION

a Michigan nonprofit corporation, was incorporated on March 2, 2001 and said corporation is in existence under the laws of this State.

This certificate is issued to attest to the fact that the corporation is in good standing in this office as of this date and is duly authorized to transact business or conduct affairs in Michigan and for no other purpose. It is in the usual form, made by me as the proper officer, and is entitled to have full faith and credit given it in every court and office within the United States.

In testimony whereof, I have hereunto set my hand and affixed the Seal of the Department, in the City of Lansing, this 2nd day of March, 2001.

*Andrew L. Mettelf, Director
Bureau of Commercial Services*

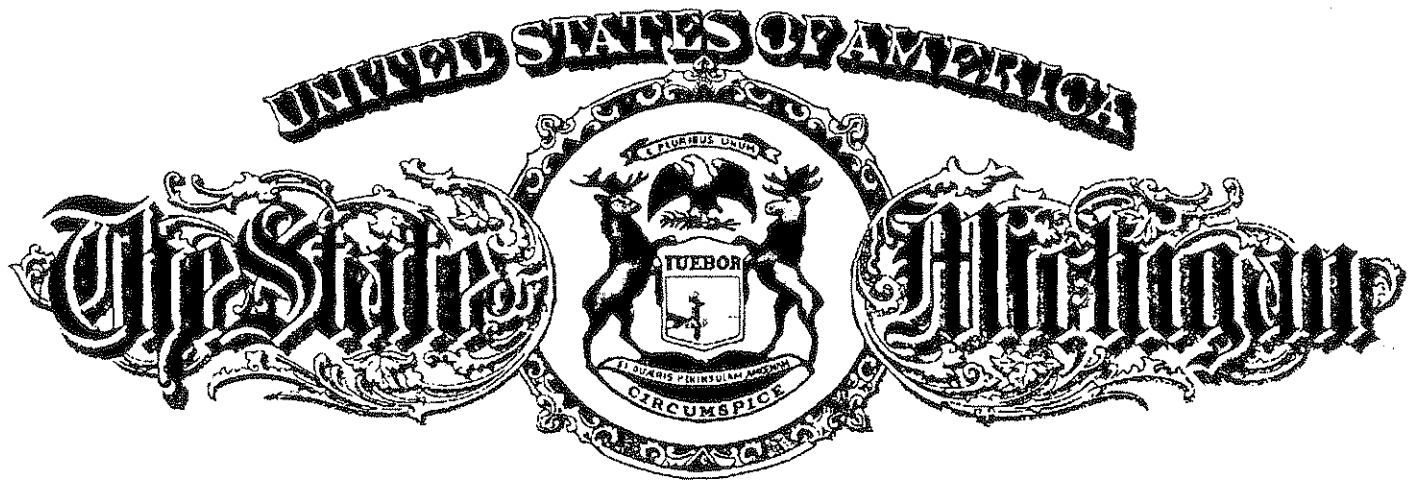

Michigan Department of Consumer and Industry Services

Lansing, Michigan

This is to Certify that the annexed copy has been compared by me with the record on file in this Department and that the same is a true copy thereof.

This certificate is in due form, made by me as the proper officer, and is entitled to have full faith and credit given it in every court and office within the United States.

In testimony whereof, I have hereunto set my hand, in the City of Lansing, this 6th day of March, 2001

Andrew J. Mettler, Director
Bureau of Commercial Services

045502

MCR-03-2001-14-37

HMS-C

770-116

P-02-09

RECEIVED

FILED

MAR 02 2001

ARTICLES OF INCORPORATION

MAR 02 2001

MI DEPT. OF CONSUMER & INDUSTRY SERVICES
BUREAU OF COMMERCIAL SERVICES

MICHIGAN NON-PROFIT CORPORATION

Administrative
BUREAU OF COMMERCIAL SERVICES

Pursuant to the provisions of Act 162, Public Acts of 1982, the undersigned execute the following Articles:

ARTICLE I

The name of the corporation is River Park Village Condominium Homeowners' Association.

ARTICLE II

The purposes for which the corporation is organized are:

(a) To manage and administer the affairs of and to maintain River Park Village Condominium, a residential condominium, according to the Master Deed recorded in Liber 22409, Page 004, Oakland County Records, being Oakland County Condominium Subdivision Plan No. 1332, located in the City of Northville, Oakland County, Michigan (hereinafter called "Condominium");

(b) To levy and collect assessments against and from the co-owner members of the corporation and to use the proceeds thereof for the purposes of the corporation;

(c) To carry insurance and to collect and allocate the proceeds thereof;

(d) To rebuild improvements after casualty;

(e) To contract for and employ persons, firms, or corporations to assist in management, operation, maintenance, and administration of the Condominium;

(f) To make and enforce reasonable regulations concerning the use and enjoyment of the Condominium;

(g) To own, maintain and improve, and to buy, or operate, manage, sell, convey, assign, mortgage, or lease (as landlord or tenant) any real and personal property, (including Condominium units, easements, rights-of-way and licenses) on behalf of the corporation, for the purpose of providing benefit to the members of the corporation and in furtherance of any of the purposes of the corporation;

(h) To borrow money and issue evidences of indebtedness in furtherance of any or all of the objects of its business; to secure the same by mortgage, pledge or other lien;

22³⁰ 109528 CK See



(i) To enforce the provisions of the Master Deed and Bylaws of the Condominium and of these Articles of Incorporation and such rules and regulations of the corporation as may hereafter be adopted;

(j) To sue in all courts and participate in actions and proceedings judicial, administrative, arbitative or otherwise, subject to the express limitations on suits, actions and proceedings as set forth in Article IX of these Articles;



(k) To do anything required of or permitted to it as administrator of the Condominium by the Condominium Master Deed or Bylaws or by the Michigan Condominium Act; and

(l) To make and perform any contract and to exercise all powers necessary, incidental or convenient to the administration, management, maintenance, repair, replacement and operation of the Condominium and to the accomplishment of any of the purposes thereof.

ARTICLE III

The corporation is organized upon a nonstock, membership basis.

The assets of the corporation are:

Real Property: None
Personal Property: None

The corporation is to be financed under the following general plan:

Assessment of members owning units in the Condominium.

ARTICLE IV

The address of the registered office is:

32000 Northwestern Highway
Suite 220
Farmington Hills, Michigan 48334

The mailing address of the registered office is the same as above.

The name of the first resident agent at the registered office is: Scott P. Drumm

ARTICLE IV

The name and business address of the incorporator is:

River Park Village Building Co., L.L.C.
32000 Northwestern Highway
Suite 220
Farmington Hills, Michigan 48334

ARTICLE VI

The term of the corporate existence is perpetual.

ARTICLE VII

The qualifications of members, the manner of their admission to the corporation, the termination of membership, and voting by the members shall be as follows:

(a) Each co-owner (including the Developer named in the Condominium Master Deed) of a unit in the Condominium shall be a member of the corporation, and no other person or entity shall be entitled to membership.

(b) Membership in the corporation shall be established by the acquisition of fee simple title to a unit in the Condominium and by recording with the Register of Deeds in the County where the Condominium is located a deed or other interest establishing a change of record title to such unit and the furnishing of evidence of same satisfactory to the corporation (except that the Developer of the Condominium shall become a member immediately upon establishment of the Condominium), the new co-owner thereby becoming a member of the corporation, and the membership of the prior co-owner thereby being terminated. Land contract vendees of units shall be members if the land contract instrument expressly conveys the vendor's interest as a member of the corporation, in which event the vendor's membership shall terminate as to the unit sold.

(c) The share of a member in the funds and assets of the corporation cannot be assigned, pledged, encumbered or transferred in any manner except as an appurtenance to the member's unit in the Condominium.

(d) Voting by members shall be in accordance with the provisions of the Bylaws of this corporation.

ARTICLE VIII

A volunteer director (as defined in Section 110 of Act 162, Public Acts of 1982, as amended) of the corporation shall not be personally liable to the corporation or its members for monetary damages for breach of the director's fiduciary duty arising under any applicable law. However, this Article shall not eliminate or limit the liability of a director for any of the following:

- (1) A breach of the director's duty of loyalty to the corporation or its members.
- (2) Acts or omission not in good faith or that involve intentional misconduct, a knowing violation of law, or failure to follow the Bylaws of the corporation or these Articles.
- (3) A violation of Section 551(l) of Act 162, Public Acts of 1982, as amended.
- (4) A transaction from which the director derived an improper personal benefit.
- (5) An act or omission occurring before the date this document is filed.
- (6) An act or omission that is grossly negligent.

Any repeal or modification of this Article shall not adversely affect any right or protection of any director of the corporation existing at the time of, or for or with respect to, any acts or omissions occurring before such repeal or modification.

ARTICLE IX

The requirements of this Article IX shall govern the corporation's commencement and conduct of any civil action except for actions to enforce the Bylaws of the corporation or collect delinquent assessments. The requirements of this Article IX will ensure that the members of the corporation are fully informed regarding the prospects and likely costs of any civil action the corporation proposes to engage in, as well as the ongoing status of any civil actions actually filed by the corporation. These requirements are imposed in order to reduce both the cost of litigation and the risk of improvident litigation, and in order to avoid the waste of the corporation's assets in litigation where reasonable and prudent alternatives to the litigation exist. Each member of the corporation shall have standing to sue to enforce the requirements of this Article IX. The following procedures and requirements apply to the corporation's commencement of any civil action other than an action to enforce the Bylaws of the corporation or collect delinquent assessments:

(a) The Association's Board of Directors ("Board") shall be responsible in the first instance for recommending to the members that a civil action be filed, and supervising and directing any civil actions that are filed.

(b) Before an attorney is engaged for purposes of filing a civil action on behalf of the corporation, the Board shall call a special meeting of the members of the corporation ("litigation evaluation meeting") for the express purpose of evaluating the merits of the proposed civil action. The written notice to the members of the date, time and place of the litigation evaluation meeting shall be sent to all members not less than twenty (20) days before the date of the meeting and shall include the following information copied onto 8-1/2" x 11" paper:

(1) A certified resolution of the Board setting forth in detail the concerns of the Board giving rise to the need to file a civil action and further certifying that:

(a) it is in the best interests of the corporation to file a lawsuit;

(b) that at least one Board member has personally made a good faith effort to negotiate a settlement with the putative defendant(s) on behalf of the corporation, without success;

(c) litigation is the only prudent, feasible and reasonable alternative;
and

(d) the Board's proposed attorney for the civil action is of the written opinion that litigation is the corporation's most reasonable and prudent alternative.

(2) A written summary of the relevant experience of the attorney ("litigation attorney") the Board recommends be retained to represent the corporation in the proposed civil action, including the following information:

(a) the number of years the litigation attorney has practiced law; and

(b) the name and address of every condominium and homeowner association for which the attorney has filed a civil action in any court, together with the case number, county and court in which each civil action was filed.

(3) The litigation attorney's written estimate of the amount of the corporation's likely recovery in the proposed lawsuit, net of legal fees, court costs, expert witness fees and all other expenses expected to be incurred in the litigation.

(4) The litigation attorney's written estimate of the cost of the civil action through a trial on the merits of the case ("total estimated cost"). The total estimated cost of the civil action shall include the litigation attorney's expected fees, court costs, expert witness fees, and all other expenses expected to be incurred in the civil action.

(5) The litigation attorney's proposed written fee agreement.

(6) The amount to be specially assessed against each unit in the Condominium to fund the estimated cost of the civil action both in total and on a monthly per unit basis, as required by subparagraph (f) of this Article IX.

(c) If the lawsuit relates to the condition of any of the common elements of the Condominium, the Board shall obtain a written independent expert opinion as to reasonable and practical alternative approaches to repairing the problems with the common elements, which shall set forth the estimated costs and expected viability of each alternative. In obtaining the independent expert opinion required by the preceding sentence, the Board shall conduct its own investigation as to the qualifications of any expert and shall not retain any expert recommended by the litigation attorney or any other attorney with whom the Board consults. The purpose of the independent expert opinion is to avoid any potential confusion regarding the condition of the common elements that might be created by a report prepared as an instrument of advocacy for use in a civil action. The independent expert opinion will ensure that the members of the corporation have a realistic appraisal of the condition of the common elements, the likely cost of repairs to or replacement of the same, and the reasonable and prudent repair and replacement alternatives. The independent expert opinion shall be sent to the members with the written notice of the litigation evaluation meeting.

(d) The corporation shall have a written fee agreement with the litigation attorney, and any other attorney retained to handle the proposed civil action. The corporation shall not enter into any fee agreement that is a combination of the retained attorney's hourly rate and a contingent fee arrangement unless the existence of the agreement is disclosed to the members in the text of the corporation's written notice to the members of the litigation evaluation meeting.

(e) At the litigation evaluation meeting the members shall vote on whether to authorize the Board to proceed with the proposed civil action and whether the matter should be handled by the litigation attorney. The commencement of any civil action by the corporation (other than a suit to enforce the Condominium Bylaws or collect delinquent assessments) shall require the approval of seventy-five percent (75%) in number and in value of all of the members of the corporation. Any proxies to be voted at the litigation evaluation meeting must be signed at least seven (7) days prior to the litigation evaluation meeting.

(f) All legal fees incurred in pursuit of any civil action that is subject to this Article IX shall be paid by special assessment of the members of the corporation ("litigation special assessment"). The litigation special assessment shall be approved at the litigation evaluation meeting (or at any subsequent duly called and noticed meeting) by a majority in number and in

value of all members of the corporation in the amount of the estimated total cost of the civil action. If the litigation attorney proposed by the Board is not retained, the litigation special assessment shall be in an amount equal to the retained attorney's estimated total cost of the civil action, as estimated by the attorney actually retained by the corporation. The litigation special assessment shall be apportioned to the members in accordance with their respective percentage of value interests in the Condominium and shall be collected from the members on a monthly basis. The total amount of the litigation special assessment shall be collected monthly over a period not to exceed twenty-four (24) months.

(g) During the course of any civil action authorized by the members pursuant to this Article IX, the retained attorney shall submit a written report ("attorney's written report") to the Board every thirty (30) days setting forth:

(1) The attorney's fees, the fees of any experts retained by the attorney, and all other costs of the litigation during the thirty (30) day period immediately preceding the date of the attorney's written report ("reporting period").

(2) All actions taken in the civil action during the reporting period, together with copies of all pleadings, court papers and correspondence filed with the court or sent to opposing counsel during the reporting period.

(3) A detailed description of all discussions with opposing counsel during the reporting period, written and oral, including, but not limited to, settlement discussions.

(4) The costs incurred in the civil action through the date of the written report, as compared to the attorney's estimated total cost of the civil action.

(5) Whether the originally estimated total cost of the civil action remains accurate.

(h) The Board shall meet monthly during the course of any civil action to discuss and review:

- (1) the status of the litigation;
- (2) the status of settlement efforts, if any; and
- (3) the attorney's written report.

(i) If, at any time during the course of a civil action, the Board determines that the originally estimated total cost of the civil action or any revision thereof is inaccurate, the Board shall immediately prepare a revised estimate of the total cost of the civil action. If the revised estimate exceeds the litigation special assessment previously approved by the members, the Board shall call a special meeting of the members to review the status of the litigation, and to

allow the members to vote on whether to continue the civil action and increase the litigation special assessment. The meeting shall have the same voting requirements as a litigation evaluation meeting.

(j) The attorneys' fees, court costs, expert witness fees and all other expenses of any civil action subject to this Article IX ("litigation expenses") shall be fully disclosed to members in the corporation's annual budget. The litigation expenses for each civil action subject to this Article IX shall be listed as a separate line item captioned "litigation expenses" in the corporation's annual budget.

ARTICLE X

These Articles of Incorporation may only be amended by the consent of seventy-five percent (75%) of all members.

I, the incorporator, sign my name this ____ day of January, 2001.

RIVER PARK VILLAGE BUILDING CO., L.L.C.,
a Michigan limited liability company

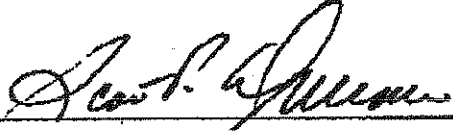
By: 

Its: MEMBER

DET_C3391507.1

DOCUMENT WILL BE RETURNED TO NAME AND MAILING ADDRESS
INDICATED IN THE BOX BELOW. Include name, street and number
(or P.O. box), city, state and ZIP code.

HONIBMAN MILLER SCHWARTZ & COHN
%KATH LAFORGIA
222 N WASHINGTON SQ STE 400
LANSING MI 48933

IV. ESCROW AGREEMENT

COPY

RIVER PARK VILLAGE CONDOMINIUM

ESCROW AGREEMENT

THIS ESCROW AGREEMENT ("Agreement") is made as of January 3, 2001, between RIVER PARK VILLAGE BUILDING CO., L.L.C., a Michigan limited liability company ("Builder"), and FIDELITY TITLE CO., a Michigan corporation ("Escrow Agent").

RECITALS:

A. Builder is the developer of River Park Village Condominium, a residential condominium located in Northville, Michigan.

B. Builder is selling homes built in units ("Units") in River Park Village Condominium and is entering into construction and sales agreements (collectively, "Purchase Agreements" and individually, a "Purchase Agreement") and/or reservation agreements (collectively, "Reservation Agreements" and individually, a "Reservation Agreement") in substantially the form attached hereto which provide for the sale of such Units and which require that deposits be held in an escrow account with Escrow Agent.

C. Builder and Escrow Agent desire to enter into this Escrow Agreement to establish an escrow account for the benefit of Builder and for the benefit of the purchasers of Units in River Park Village Condominium.

D. Escrow Agent is acting as an independent party hereunder pursuant to this Escrow Agreement and the Michigan Condominium Act (Act No. 59, Public Acts of 1978, as amended, hereinafter the "Act") for the benefit of Builder and all purchasers and not as the agent of any one or less than all of such parties.

NOW, THEREFORE, it is agreed as follows:

1. Builder shall, promptly after receipt, transmit to Escrow Agent all sums deposited for escrow under a Purchase Agreement or Reservation Agreement, together with a fully executed copy of such Agreement. If a purchaser who has deposited funds under a Reservation Agreement subsequently signs a Purchase Agreement, such funds shall be treated as a deposit under the Purchase Agreement. If a purchaser who has deposited funds under a Reservation Agreement withdraws from such Reservation Agreement prior to signing a Purchase Agreement, then the Deposit under the Reservation Agreement shall promptly be refunded to such purchaser.

2. The sums paid to Escrow Agent under the terms of any Purchase Agreement shall be held by Escrow Agent and released to Builder or purchaser as follows:

A. The escrowed funds shall be released to purchaser upon the following circumstances:

(i) If the Purchase Agreement is contingent upon purchaser obtaining a mortgage and purchaser diligently pursues a mortgage application but fails to obtain such mortgage, Escrow Agent shall release to purchaser all sums held by it pursuant to said Purchase Agreement.

(ii) In the event that a purchaser duly withdraws from a Purchase Agreement prior to the time the Purchase Agreement becomes binding under Paragraph 2 thereof, Escrow Agent shall, within three business days from the date of receipt of written notice of such withdrawal, release to purchaser all of purchaser's deposits held thereunder.

B. After a Purchase Agreement has become binding upon the purchaser, then Escrow Agent shall release sums held pursuant to the Purchase Agreement to Builder in accordance with the terms of said Purchase Agreement.

C. It is understood that the Builder will be depositing only the purchaser's initial deposit with Escrow Agent, to be held and delivered in accordance with the terms and conditions of this Agreement, said sum being deemed to relate to the purchase of the condominium Unit described in the Purchase Agreement and/or Reservation Agreement. It is further understood and agreed that all other sums ("progress payments") under the Purchase Agreement relate to the construction of the Unit and that all such progress payments will be paid directly to Builder by the purchaser and will not be placed in escrow with Escrow Agent.

D. Escrow Agent shall be under no obligation to earn interest upon the escrowed sums held pursuant hereto. In the event that interest upon such sums is earned, however, all such interest shall be separately accounted for by Escrow Agent and shall be held in escrow and released as and when principal deposits are released hereunder; provided, however, that all interest earned on deposits refunded to a purchaser upon such purchaser's withdrawal from a Purchase Agreement shall be paid to Builder. Any interest paid to Builder shall not be credited to purchaser for any reason.

E. If Builder requests that all or any portion of the escrowed funds held hereunder be delivered to it prior to the time it otherwise becomes entitled to receive such funds, Escrow Agent may release such funds to Builder if Builder has placed with Escrow Agent security in form and substance satisfactory to Escrow Agent securing full repayment of said sums, as may be permitted by law.

F. Notwithstanding any other provision herein to the contrary, Escrow Agent shall be under no obligation to release funds deposited hereunder to any party until it can satisfactorily ascertain that the funds deposited have been paid, settled and fully collected as such terms are defined under the provisions of MCL 440.4101, et seq.

3. Escrow Agent may require reasonable proof of occurrence of any of the events, actions or conditions stated herein before releasing any sums held by it pursuant to any Purchase Agreement or Reservation Agreement either to a purchaser thereunder or to Builder.

4. Upon release of the funds deposited with Escrow Agent pursuant to any Purchase Agreement or Reservation Agreement and this Agreement, Escrow Agent shall be released from any further liability, it being expressly understood that Escrow Agent's liability is limited by the terms and provisions set forth in this Agreement, and that by acceptance of any escrow deposit, Escrow Agent is acting in the capacity of a depository and is not, as such, responsible or liable for the sufficiency, correctness, genuineness or validity of the instruments submitted to it, or the marketability of title to any Unit. Escrow Agent is not responsible for the failure of any bank used by it as a depository for funds received by it under this Escrow Agreement. Escrow Agent is not a guarantor of performance by Builder under the condominium documents or any Purchase Agreement or Reservation Agreement. Escrow Agent undertakes no responsibilities whatever with respect to the nature, extent or quality of Builder's actions or performance of Builder's obligations. As long as Escrow Agent relies in good faith upon any certificate, cost estimate or determination provided for herein, Escrow Agent shall have no liability whatever to Builder, any purchaser, any co-owner or any other party for any error in such certificate, cost estimate or determination or for any act or omission by Escrow Agent in reliance thereon. Escrow Agent's liability hereunder shall in all events be limited to return, to the party or parties entitled thereto, of the funds deposited in escrow less any reasonable expenses which Escrow Agent may incur in the administration of such funds or otherwise hereunder, including, without limitation, reasonable attorneys' fees and litigation expenses paid in connection with the defense, negotiation or analysis of claims against it, by reason of litigation or otherwise, arising out of the administration of such escrowed funds, all of which costs Escrow Agent shall be entitled without notice to deduct from amounts on deposit hereunder.

5. All notices required or permitted hereunder and all notices of change of address shall be deemed sufficient if personally delivered or sent by registered mail, postage prepaid and return receipt requested, addressed to the recipient party at the address shown below such party's signature to this Agreement or upon the applicable Purchase Agreement or Reservation Agreement. For purposes of calculating time periods under the provisions of this Agreement, notice shall be deemed effective upon mailing or personal delivery, whatever is applicable.

IN WITNESS WHEREOF, the parties have executed this Agreement.

BUILDER:

RIVER PARK VILLAGE BUILDING
CO., L.L.C.,
a Michigan limited liability company

By: _____

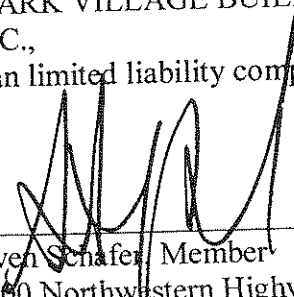
Steven Schafel, Member
32000 Northwestern Highway
Suite 220
Farmington Hills, Michigan 48334

ESCROW AGENT:

FIDELITY TITLE CO.,
a Michigan corporation

By: _____

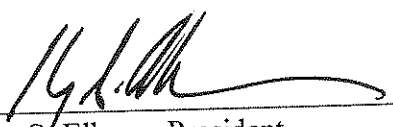
Harry S. Ellman, President
32100 Telegraph Road, Suite 215
Bingham Farms, Michigan 48025

Attachments:

Reservation Agreement
Purchase Agreement

DET_C\371951.1

ATTACHMENT TO ESCROW AGREEMENT

RIVER PARK VILLAGE CONDOMINIUM

RESERVATION AGREEMENT

The persons signing below ("Purchaser") reserve the right to purchase a unit ("Unit") in River Park Village Condominium, Northville, Michigan according to the following terms and conditions.

1. River Park Village Building Co., L.L.C., a Michigan limited liability company ("Developer"), agrees to reserve Unit No. _____, as shown on Developer's proposed site plan.

2. In consideration of such reservation, Purchaser agrees to deposit the sum of \$1,000.00 ("Deposit") to be held in escrow by Philip R. Seaver Title Company, Inc. ("Escrow Agent"), pursuant to an Escrow Agreement with Developer. Purchaser acknowledges receipt of the Escrow Agreement, and the terms thereof are incorporated herein by this reference.

3. If this Reservation Agreement has not been cancelled as provided below, Purchaser agrees to sign a binding Construction and Sales Agreement for the Unit within five (5) days after being requested to do so by Developer. The terms of the Construction and Sales Agreement, including the price of the Unit, shall be in the sole discretion of Developer. The Deposit shall be applied against any deposits due under the Construction and Sales Agreement.

4. Purchaser may withdraw from this Reservation without further obligation at any time prior to signing a binding Construction and Sales Agreement. Developer may cancel this Reservation Agreement at any time for any of the following reasons: (a) Developer decides not to build the improvements or sell Purchaser's Unit, (b) Purchaser fails to sign a Construction and Sales Agreement or provide personal or financial information within five (5) days of being asked to do so by Developer, or (c) Developer decides, in its sole discretion, that it is unlikely that Purchaser will be financially capable of purchasing the Unit.

5. If Purchaser decides to withdraw from this Reservation Agreement, or if Developer cancels this Reservation Agreement, then the Deposit shall be refunded to Purchaser in full within three (3) business days after Escrow Agent, Purchaser and Developer have received written notice of such withdrawal or cancellation.

6. This Reservation Agreement is not a Construction and Sales Agreement. No lien of any kind is acquired by Purchaser either upon the Unit or upon any part of River Park Village Condominium. The location, size or design of any Unit, including Purchaser's Unit, may be changed in Developer's discretion. The liability of Developer under this Reservation Agreement is at all times limited to the return of the Deposit without interest.

7. All notices given pursuant to this Reservation Agreement shall be in writing and shall be hand-delivered or mailed by first class mail or by registered or certified mail.

Dated: _____

DEVELOPER:

PURCHASER:

RIVER PARK VILLAGE BUILDING CO., L.L.C.,
a Michigan limited liability company

By: _____
*

Its: Authorized Agent

*

*

Developer's Address:

Purchaser's Address:

32000 Northwestern Highway
Suite 220
Farmington Hills, Michigan 48334
(248) 851-9900

Home Phone No.: _____

Work Phone No.: _____

* Print or type name beneath signature.

DET_C\371954.1

ATTACHMENT TO ESCROW AGREEMENT

CONSTRUCTION AND SALES AGREEMENT

Unit No. _____

Address: _____

River Park Village Condominium
Wayne County Condominium Subdivision Plan No. 1332
Northville, Michigan

The purchaser identified below ("Purchaser") agrees to purchase the condominium unit ("Unit") described above within the River Park Village Condominium ("Condominium") and the improvements to be made therein (collectively, the "Home") from River Park Village Building Co., L.L.C., a Michigan limited liability company ("Builder"), according to the following terms and conditions. The Unit and the Home are referred to collectively below as the "Property". Subject to the terms of this Agreement, the Home shall be built substantially in accordance with plans and specifications (together, collectively, the "Specifications" and individually, a "Specification") on file at the office of Builder, which Purchaser has examined and approved, and which are incorporated herein by reference. The purchase price ("Purchase Price") for the Property is as follows:

BASE PRICE \$ _____
(See Exhibit A hereto)

CUSTOM OPTIONS \$ _____
(See Exhibit A hereto)

TOTAL PURCHASE PRICE \$ _____

1. The sale is to be consummated by delivery of a Warranty Deed conveying marketable title to the Property subject to easements, restrictions and agreements of record, the lien of taxes and assessments not yet due and payable as of Closing (defined below) and the River Park Village Condominium Master Deed ("Master Deed"). Payment of the Purchase Price shall be made by certified check and shall be paid pursuant to the schedule set forth in Exhibit B hereto.

2. (a) The Deposit referred to in Exhibit B hereto shall be deposited in an escrow account with Fidelity Title Co. ("Escrow Agent"), whose address is 32100 Telegraph Road, Suite 215, Bingham Farms, Michigan 48025, as Escrow Agent, and, in the event Purchaser, other than by reason of Purchaser's default, withdraws from this Construction and Sales Agreement ("Agreement"), the Deposit shall be returned to the Purchaser within three business days after such withdrawal, all as provided in subparagraph (b) below. The escrow agreement between Builder and Escrow Agent is incorporated herein by reference.

(b) Unless Purchaser waives the right of withdrawal, Purchaser may withdraw from this Agreement without cause and without penalty if the withdrawal is made before conveyance of the Unit and within nine business days after receipt of the documents required to be delivered to Purchaser pursuant to Section 8 below, including the day on which the documents are received if that day is a business day.

(c) After expiration of the withdrawal period, Purchaser acknowledges that Builder shall be paid the Deposit by Escrow Agent, notwithstanding any provision hereof to the contrary. Purchaser acknowledges that no portion of the improvements shown on the

condominium plan attached to the Master Deed have been labeled "must be built."

(d) This Agreement shall not be binding upon Purchaser until Purchaser's right to withdraw herefrom has expired in accordance with subparagraph (b) above or has been waived by Purchaser in accordance with the Michigan Condominium Act, as amended.

3. As evidence of title, Builder agrees to furnish Purchaser with a commitment for an owner's policy of title insurance to be issued by Escrow Agent, bearing a date later than the acceptance hereof, and guaranteeing title to the Property in the condition required by this Agreement and a survey certified to Purchaser. If objection to the state of title as disclosed by the commitment is made based upon the written opinion of Purchaser's attorney, delivered to Builder within 10 days following Purchaser's receipt of the title commitment, indicating that title to the Property is not marketable, Builder shall have 30 days from the date it is notified in writing of the particular defects claimed either (a) to fulfill the requirements in the commitment or to remedy the title defects set forth in such attorney's opinion, or (b) to refund the Deposit referred to in Exhibit A hereto in full termination of this Agreement.

4. The closing ("Closing") of the sale of the Property shall take place at the office of Escrow Agent within five (5) days after the later of the Builder's delivery of the title insurance commitment to Purchaser or completion of construction. Issuance of a temporary or final certificate of occupancy shall constitute completion of construction and acceptance of the Property.

5. In the event that this Agreement is not fully or timely performed by Purchaser, Builder may declare a default hereunder by sending written notice to Purchaser. If Purchaser fails to cure fully such default within five (5) days after receipt of such notice of default, or if such default, by its nature, cannot be cured, Builder may (a) elect to terminate this Agreement upon notice to Purchaser, in which case all payments made to Builder hereunder shall be forfeited to Builder, Builder may recover such other damages as may be owing to it and Builder may dispose of the Property as it sees fit, or (b) elect, without further notice to Purchaser, to treat this Agreement as remaining in full force and effect and pursue an action against Purchaser for specific performance or damages or both. At the exclusive option of the Purchaser, any claim which might be the subject of a civil action against Builder which involves an amount less than \$2,500.00, and arises out of or relates to this Agreement or the Unit or the Condominium, shall be settled by binding arbitration conducted by the American Arbitration Association. The arbitration shall be conducted in accordance with applicable law and the currently applicable rules of the American Arbitration Association. Judgment upon the award rendered by arbitration may be entered in the circuit court of appropriate jurisdiction, provided the award does not exceed \$2,500.00 in favor of any party.

6. Purchaser shall be entitled to possession at the conclusion of the Closing.

7. An association of owners ("Association") has been established as a Michigan non-profit corporation for the purpose of operating and maintaining the common elements of the Condominium. Each owner of a Unit will be a member of the Association. Purchaser agrees to abide by the terms and provisions contained in the Master Deed, condominium bylaws and articles of incorporation of the Association. As a member of the Association, Purchaser will be obligated to pay a proportionate share of the Association assessments for maintenance, repair, replacement and other expenses of administration. Purchaser shall not have the rights or obligations of a co-owner or Association member until the Closing.

8. Purchaser acknowledges receipt of the following documents ("Condominium Documents"): (a) the recorded Master Deed and exhibits and amendments thereto; (b) a copy of this Agreement together with a copy of the escrow agreement described in Section 2 above; (c) a copy of the Condominium Buyer's Handbook prepared by the Michigan Department of Consumer and Industry Services; and (d) a disclosure statement. Any of the Condominium Documents (except this Agreement) may be amended without Purchaser's consent provided that Purchaser may, prior to Closing, withdraw from this Agreement without penalty (and receive back the Deposits) if any such amendment materially reduces any of Purchaser's rights. The Condominium Documents including any amendments must comply with the provisions of the

Michigan Condominium Act, as amended.

9. All taxes and assessments which have become a lien upon the Property and which are due and payable at the date of Closing shall be paid by the Builder, excepting current taxes which shall be pro-rated and adjusted to the date of Closing on the due date basis (to the extent that the then current tax bill(s) covers all of the property in the Condominium (as opposed to merely the Property), prior to such proration, the amounts owing thereon shall be allocated among the units within the Condominium in accordance with the percentages of value allocated to each unit in the Condominium in the Master Deed). Any Association assessment against the Property due at the time of Closing will be paid by Builder, and Purchaser will reimburse Builder for a portion of the current annual assessment prorated to the day of Closing. Purchaser, at the time of Closing, will pay the Association a sum equal to the annual assessment, and Purchaser shall comply with any of the lawful requirements of the Association. If, at or after Closing, there are any property tax statements issued affecting the Condominium as a whole, Purchaser will pay a pro rata share of the tax in accordance with the percentage of value allocated to Purchaser's Unit in the Master Deed. The payment of the transfer tax on the deed from Builder to Purchaser shall be EQUALLY SHARED by Builder and Purchaser.

10. Builder shall complete the construction of the Home within twenty-four (24) months from the date of ground-breaking, subject only to delays caused by acts of God, material shortages, labor strikes or other conditions beyond the reasonable control of the Builder.

11. Purchaser agrees that Builder shall not be required to make any alterations or variations in the construction of the Home not provided for in the Specifications and that Builder shall not be required to provide any so-called "extras". Subject to the provisions of Section 12 hereof, no agreement to provide extras purportedly entered into subsequent to this Agreement shall be binding upon Builder unless it is in writing and signed by Builder and Purchaser has paid to Builder, in advance, the full cost of such extras.

12. The construction of the Home shall be in substantial compliance with the Specifications, but subject in all respects to, among other things, any modifications to the Specifications necessitated by field conditions, the availability of materials or labor, the requirements of building authorities or other factors. If any modifications substantially diminish the fair market value and utility of the Home, Purchaser's sole and exclusive remedy on account thereof prior to Closing shall be to terminate this Agreement and receive a refund of the Deposit. In the event (a) any modifications discovered prior to Closing do not substantially diminish the fair market value of the Home, or (b) modifications of any kind are discovered subsequent to Closing by either Builder or Purchaser, or (c) in the event any particular item provided for in the Specifications is not installed by Builder and the same is discovered subsequent to Closing by either Builder or Purchaser, then, Purchaser's sole and exclusive remedy on account thereof (anything otherwise provided in law or equity to the contrary notwithstanding) shall be, with respect to modifications, the refund of the difference between Builder's cost of the applicable Specification as identified in the Specifications and Builder's cost of such Specification as modified, and, with respect to a Specification not installed, the refund of the cost of such Specification in the amount charged to Purchaser. Purchaser acknowledges that, with respect to the Home, the dimensions of the rooms, the partitions, the exterior measurements (and the like) and the materials used may vary from the Specifications. In the event of Closing, Purchaser shall be deemed to have waived any noncompliance with and/or variations from the Specifications except as otherwise provided for herein. If Builder determines that Builder is unable to satisfy the demands of Purchaser relating to the completion date for the construction of the Home or relating to the quality and standards of construction of the Home, then Builder may, at Builder's option (and without obligation to do so), and upon written notice to Purchaser, terminate this Agreement, in which event all money paid by Purchaser to Builder hereunder shall be refunded to Purchaser and neither party shall thereafter have any liability to or claim against the other.

13. All hardware, color and material selections must be made by Purchaser and received by Builder's sales department within fourteen (14) days of signing of this Agreement. If Purchaser fails to make all required selections within such fourteen (14) day period, Builder is hereby authorized to make all required selections which Purchaser has failed to make in the required period, and such selections so made by Builder will be final and binding on Purchaser. If Purchaser desires to change any selection previously made, the same shall be made only in writing, shall be allowed only in the sole discretion of Builder, and shall be subject to a processing fee of \$125.00 per change so requested by Purchaser and approved by Builder, which fee shall be paid at the time such change is approved by Builder. Builder shall have the right after Purchaser's selections have been made to reject any and all of the same and to replace any selection so rejected with a selection made by Builder; such replacement to be made at Builder's sole cost and expense. The rights and obligations of Builder and Purchaser upon Builder's failure to implement any selection made by Purchaser shall be the same as provided in Section 12 above, for modifications made to the Specifications or for a failure to install an item as provided in the Specifications, except that, in addition thereto, Builder shall return to Purchaser an amount equal to the processing fee charged for each unimplemented selection change order.

14. As a result of, among other things, safety requirements imposed by Builder's insurer, during construction, Purchaser shall not, WITHOUT THE PRIOR WRITTEN CONSENT of Builder: (a) enter the Unit or the Home; (b) interfere with any worker working on the Home; or (c) hire or employ any contractors or subcontractors to do work in or on the Home. Purchaser shall not put any furniture or personal property of any kind in the Home nor shall any person occupy the Home until Closing. In the event of any violation of the foregoing provisions by Purchaser, no matter how slight, in addition to Builder's other remedies, Builder shall have the right, but not the obligation, to terminate this Agreement and retain all sums paid hereunder by Purchaser. Notwithstanding anything herein to the contrary, during construction, Purchaser shall be entitled to inspect the Home on three (3) separate occasions while accompanied by a representative of Builder. The first of such inspections shall be after the rough mechanicals of the Home have been installed; the second such inspection shall be after the installation of carpeting in the Home; and, the final inspection shall be the walk through inspection which is to occur pursuant to the terms of the new home limited warranty to be made by Builder to Purchaser. All of such inspections shall occur only after notices from Builder to Purchaser setting forth date and time of such inspections agreed upon by Purchaser and Builder, and only during normal business hours (9:00 a.m. - 5:00 p.m.) Monday through Friday. In the event Purchaser fails to inspect the Home on any of the dates and at the times agreed upon by Purchaser and a representative of Builder in accordance with the foregoing, Purchaser shall be deemed to have waived the right of inspection with respect to the inspection so scheduled by Builder which Purchaser failed to make.

15. Purchaser acknowledges and warrants to Builder that Purchaser has read this Agreement and all exhibits attached to it, that Purchaser agrees to be bound by all of its terms and that PURCHASER IS NOT RELYING ON AND SHALL NOT HEREAFTER RELY ON ANY STATEMENT, PROMISE, CONDITION OR STIPULATION NOT SPECIFICALLY SET FORTH IN THIS AGREEMENT. Purchaser further acknowledges that Purchaser has read and understands the Condominium Documents and agrees to be bound by all of the terms thereof. Purchaser acknowledges that Builder has made no representations as to the resale value of the Property or of the River Park Village Condominium development.

16. The only warranty made by Builder regarding the Property is contained in a separate new home limited warranty, a copy of which is attached hereto as Exhibit C. There are no other warranties, express or implied, in connection with the construction of the Home and the sale of the Property to Purchaser. Except as expressly provided in Section 12 hereof, such new home limited warranty shall exclusively govern any claim (or claims) asserted after Closing which Purchaser may have against Builder with respect to or arising out of the condition or construction of the Home, and, Purchaser hereby waives and, following the Closing shall not assert, in contract or tort, any claim (hereafter an "Unauthorized Legal Claim") arising with respect to the condition or construction of the Home except to the extent, and only to the extent, a contract claim may be asserted to enforce such new home limited warranty or the provisions of Section 12 hereof. If Purchaser asserts an Unauthorized Legal Claim, Purchaser shall be liable to Builder for all losses, damages, costs and expenses suffered or incurred by Builder by reason of

such Unauthorized Legal Claim, such costs to include, by way of description and not limitation, all actual attorneys' fees incurred by Builder in defense of the Unauthorized Legal Claim and in the enforcement of Builder's rights as set forth herein. The provisions of this Section shall survive the Closing of the sale of the Property by Builder to Purchaser and shall be and remain binding thereafter.

17. This Agreement contains all of the representations and obligations of the parties hereto and any modifications or changes to this Agreement shall be made, if at all, only in writing and signed by the parties hereto before the same shall be binding. Purchaser acknowledges that it is Builder's procedure to cause one of the members of Builder to execute this Agreement and to initial all of the pages of this Agreement, including its exhibits. To the extent that all of such pages have not been so initialed by one of the members of Builder, then, such pages not so initialed shall not be deemed in full force and effect and binding upon Builder unless Builder subsequently consents thereto in writing and duly executed by one of the members of Builder. In no event shall Purchaser have the right to rely upon the execution of the Agreement, any amendment of the terms hereof, or any agreement supplemental hereto unless signed by one of the Members of Builder; and, no documents signed or initialed and no representation or agreement made by any purported representative of Builder shall be binding upon Builder without a duly executed resolution signed by all of the members of Builder indicating the authority of the parties executing this Agreement, any such amendment of the terms hereof or any such oral or written agreement supplemental hereto being of no force or effect. This Agreement may be assigned by Builder, but is not assignable by Purchaser without the prior written consent of Builder. It is expressly understood and agreed that neither this Agreement nor any other document which shall assert an interest of Purchaser in the Property shall be recorded by Purchaser prior to Closing. In the event Purchaser shall violate the provisions of this Section relating to recording, the same shall constitute an automatic default under the terms and conditions of this Agreement, thereby entitling Builder to terminate this Agreement by written notice thereof to Purchaser, in which event all sums paid hereunder by Purchaser to Builder shall be retained by Builder as liquidated damages and neither party hereto shall otherwise have any further liability or obligation hereunder.

18. Notwithstanding any provision of this Agreement to the actual or apparent contrary, Purchaser covenants and agrees that it will not file or assert, or consent to the filing or assertion of, any claim against Builder (or any officer, director or employee of Builder) (hereafter individually and collectively referred to as "Builder") before any court or administrative agency of government, unless the claim constitutes, in all respects, an enforceable claim which Purchaser would otherwise have against Builder, at law or in equity, by reason of an uncured breach or default by Builder of the terms of this Agreement or of the new home limited warranty given pursuant to the terms hereof. If Purchaser shall file or assert such a claim (the "Unauthorized Administrative Claim") then Purchaser shall be deemed in default of this Agreement and shall be liable to Builder for all losses, damages, costs and expenses suffered or incurred by Builder by reason of such Unauthorized Administrative Claim, such costs to include by way of description but not limitation, all actual attorneys' fees incurred by Builder in the defense of the Unauthorized Administrative Claim and in the enforcement of Builder's rights as herein set forth. The provisions of this Section shall survive the Closing and shall be and remain binding thereafter. For the purposes of this Section, no failure of Builder to remedy a deficiency in construction shall be deemed an uncured default of Builder hereunder or under the new home limited warranty unless Builder fails to cure such deficiency within four months following the expiration of the one year term of the new home limited warranty.

19. In the event of any litigation (e.g., in any court in the State of Michigan or any other state or before any administrative body or through any arbitration or mediation proceeding) commenced by Purchaser against Builder or any of its affiliates or members relating to this Agreement and the transaction contemplated hereby, to the extent Purchaser fails to obtain the exact relief sought in its initial complaint, if the relief sought is other than monetary damages, and/or to the extent Purchaser fails to obtain a judgment for at least 75% of the monetary damages sought in its initial complaint, if the relief sought was monetary damages, Builder shall be entitled to recover from Purchaser all legal fees and costs incurred by Builder in connection with such litigation, whether before or after trial, administrative proceeding, arbitration or mediation through any and all appeals with respect thereto. To the extent that Purchaser has

made a claim in connection with such litigation for monetary damages and to the extent that the court, administrative body, arbitration panel or mediator, as applicable, determines that Purchaser shall be entitled to 75% or more but less than 100% of the monetary damages sought in Purchaser's initial complaint, then, Builder shall be entitled to recover a portion of its attorneys' fees and costs equal to the total of such attorneys' fees and costs multiplied by a percentage which is the percentage of the amount originally sought in Purchaser's initial complaint relating to any such litigation but not awarded in the final award.

20. This Agreement shall not be deemed binding and effective until executed and delivered by both Purchaser and Builder. Upon execution, this Agreement will be binding upon Purchaser and Builder and their respective permitted successors and assigns. The Exhibits attached hereto shall be deemed to be a part of this Agreement, the terms and provisions of which shall be incorporated into this Agreement by this reference. Time is of the essence of this Agreement.

IN WITNESS WHEREOF, the parties have executed this Agreement.

WITNESS:

"PURCHASER":

* _____

Address:

Phone: () _____

Work: () _____

Dated: _____

*Type or print names beneath signatures.

"BUILDER":

RIVER PARK VILLAGE BUILDING CO., L.L.C.

By: _____
Scott P. Drumm, Member

32000 Northwestern Highway, Suite #220
Farmington Hills, Michigan 48334
Phone: (248) 851-9900
Fax: (248) 851-1531

Dated: _____

Exhibits:

- A Custom Options
- A-1 Specifications
- B Payment Schedule
- C New Home Limited Warranty
- D Acknowledgement of No Representations
- E Financing Contingency
- F Insulation and Radon Gas Disclosure

DET_C369747.1

EXHIBIT A

CUSTOM OPTIONS SCHEDULE

The terms and provisions of this Custom Options Schedule shall be deemed to form a part of the terms and provisions of the Construction and Sales Agreement to which it is attached. In the event of a conflict between the terms and provisions of this Schedule and the terms and provisions of the Construction and Sales Agreement, the terms and provisions of this Schedule shall prevail. Capitalized terms used in the Construction and Sales Agreement shall have the same meanings when used in this Schedule.

The Purchase Price includes the cost of the options listed below. If Purchaser defaults under the Agreement, Purchaser will be liable for the cost of such options in addition to any other damages provided for in the Agreement. The options detailed below shall be built into the Home during construction pursuant to the specifications attached hereto and made a part hereof as Exhibit A-1. Purchaser has indicated its acceptance of such specifications by signing the specifications where indicated.

OPTIONS

1.	Unit Premium:	\$ _____
2.	_____	\$ _____
3.	_____	\$ _____
4.	_____	\$ _____
5.	_____	\$ _____
6.	_____	\$ _____
7.	_____	\$ _____
8.	_____	\$ _____
9.	_____	\$ _____
10.	_____	\$ _____
11.	_____	\$ _____
12.	_____	\$ _____
13.	_____	\$ _____
	TOTAL COST OF OPTIONS:	\$ <u>_____</u>
	BASE PURCHASE PRICE:	\$ _____
	TOTAL PURCHASE PRICE:	\$ <u>_____</u>

Purchaser's Initials:

_____ / _____

Builder's Initials:

River Park Village Building Co., L.L.C.

By: _____

Its: Member

EXHIBIT A-1
SPECIFICATIONS

Purchaser's Initials:

_____ / _____

Builder's Initials:

River Park Village Building Co., L.L.C.

By: _____

Its: Member

EXHIBIT B

PAYMENT SCHEDULE

The terms and provisions of this Payment Schedule shall be deemed to form a part of the terms and provisions of the Construction and Sales Agreement to which it is attached. In the event of a conflict between the terms and provisions of this Schedule and the terms and provisions of the Construction and Sales Agreement, the terms and provisions of this Schedule shall prevail. Capitalized terms used in the Construction and Sales Agreement shall have the same meanings when used in this Schedule.

1. Purchaser has agreed to pay the Purchase Price in accordance with the following payment schedule:

- (a) Deposit to be paid upon execution of the Agreement: \$7,500.00
- (b) Upon installation of basement walls: \$ _____
- (c) Upon installation of rough carpentry: \$ _____
- (d) Upon installation of the drywall: \$ _____
- (e) Upon installation of the rough mechanicals of the Home: \$ _____
- (f) Total Deposits: \$ _____
- (g) Total Balance Due at Closing: \$ _____
- (h) Total Purchase Price: \$ _____

2. Purchaser shall make the payments required upon the above-referenced installations within three (3) days after receipt of written notice from Builder that the same have been installed. Purchaser agrees that installation shall be deemed to have occurred upon receipt of such notice from Builder (without regard to any required municipal inspections).

3. In the event that the Purchaser fails to make the payment required in subsections 1(b) through 1(e) above in the amounts and upon the dates required, in addition to its other rights and remedies provided for in the Agreement, Builder shall have the right to cease all construction upon the Home. In such event, in addition to its other rights and remedies provided for in the Agreement, the amount of time within which Builder is required to complete construction of the Home shall be extended for a period of time equal to the period from the date such payment was required to have been made by Purchaser to the date such payment was actually received by Builder.

4. In the event that any item provided for in the Specifications is not readily available or has experienced a substantial and unforeseen increase in price, or in the event that any such item cannot be installed or completed in a workmanlike manner or in a manner in which Builder would be able to warrant such item as provided in the attached new home warranty, then, upon notice to Purchaser, Builder may substitute a replacement item in for any such item. The substituted item shall be of equivalent quality to the item replaced. Purchaser hereby agrees to any such substitution.

5. Purchaser may request additions to or deletions from ("Changes") the Specifications following the commencement of construction of the Home by Builder. Any such requests must be made in writing and shall only be made by Builder in the event that (a) Builder approves of such Changes in writing and determines that such Changes shall not interfere with

Purchaser's Initials:

_____ / _____

Builder's Initials:

River Park Village Building Co., L.L.C.

By: _____

Its: Member

the progress and timing of the construction of the Home, and (b) Purchaser pays all of the costs and expenses associated with the Changes at the time of acceptance of such Changes by Builder.

6. In the event Purchaser shall be financing its acquisition of the Property, Purchaser's mortgage lender, and its representatives, shall have access to the Property for the purposes of inspecting the progress of the construction of the Home. Any such access to the Property shall only be made upon the prior written approval of Builder and shall only be made provided that a representative of Builder shall accompany the person so requesting access to the Property. Builder reserves the right to refuse access to third parties in the event that Builder deems it unsafe to enter the Property.

7. In the event that Builder has not commenced construction of the Home within one (1) year from the date of the execution of the Agreement by Builder, or in the event that Builder is unable, for any reason whatsoever, to complete construction of the Home on or before the date which is one (1) year following the commencement of construction, then, Builder shall have the right to terminate the Agreement at any time thereafter and upon such termination Builder shall refund to Purchaser any and all monies paid under the Agreement and neither party shall thereafter have any further obligation under the Agreement.

8. In addition to its other rights and remedies set forth in the Agreement, in the event that Purchaser fails to close its acquisition of the Property on the date required for Closing in accordance with the Agreement, then, the Purchase Price due hereunder shall be increased by \$200.00 for each day after the date originally required for Closing which elapses prior to the actual occurrence of Closing. The foregoing shall not be deemed a penalty, but, rather, represents a portion of Builder's true and actual damages which may result in the event Closing is delayed by Purchaser.

Purchaser's Initials:

_____ / _____

Builder's Initials:

River Park Village Building Co., L.L.C.

By: _____

Its: Member

EXHIBIT C

NEW HOME LIMITED WARRANTY

Unit No.: _____

River Park Village Condominium
Northville, Michigan

This New Home Limited Warranty is made by River Park Village Building Co., L.L.C., a Michigan limited liability company ("Builder"), whose address is 32000 Northwestern Highway, Suite 220, Farmington Hills, Michigan 48334, in favor of the Purchaser identified in the Construction and Sales Agreement to which this New Home Limited Warranty is attached and is made with respect to the home ("Home") to be constructed within the Unit identified above and according to the following terms and conditions:

1. **COVERAGE.** Builder warrants, subject to the terms and exclusions set forth herein, that for the period of one (1) year after the date of Closing (identified in the Construction and Sales Agreement), the Home shall be free from substantial defects in materials and workmanship. Builder shall have until the conclusion of the four (4) month period following its receipt of Purchaser's final punch-list to remedy all outstanding warranty obligations.

2. **MANUFACTURERS' WARRANTIES.** To the extent effective on the date of Closing, Builder assigns and passes through to Purchaser, to the extent permitted by the terms of such warranties and by law, the manufacturers' and suppliers' warranties on all "Consumer Products" sold by Builder to Purchaser whether as part of the Home or separately, as the same may be defined from time to time by Public Law No. 93-637, commonly known as the "Magnuson-Moss Act", or any regulations promulgated thereunder. The following are examples of "Consumer Products", although not every home includes all of these items and some homes may include "Consumer Products" not in this list: furnaces, ranges, ovens, dishwashers, garbage disposals, hot water heaters and air conditioners. The manufacturers' warranties will be given to Purchaser at Closing. Purchaser should read them carefully. If necessary, Purchaser should mail any return post cards to record the warranties.

3. **EXCLUSIONS FROM COVERAGE.** Builder does not assume any responsibility or liability whatsoever for any defects, damages, or other matters pertaining to the following, all of which are excluded from coverage under his New Home Limited Warranty:

- (a) The roads, curbs or utility lines and other general and limited common elements within the Condominium.
- (b) Defects in "Consumer Products" as defined in the Magnuson-Moss Act or the regulations promulgated thereunder. Builder has assigned to Purchaser all warranties of "Consumer Products" furnished to Builder by suppliers or manufacturers, but those warranties will be solely the obligation of such suppliers and manufacturers and Builder has no obligation or liability with respect to those warranties. Purchaser should follow the procedures in these warranties if defects are detected in items covered by them.
- (c) Damage to the Home due to ordinary wear and tear, abusive use or lack of proper maintenance.

Purchaser's Initials:

_____ / _____

Builder's Initials:

River Park Village Building Co., L.L.C.

By: _____

Its: Member

- (d) Defects which are the result of characteristics common to the materials used, including defects which arise from normal settlement or shifting or normal expansion or contraction of the materials, and, including, without limitation, the following: warping and deflecting of wood; fading, chalking and checking paint due to sunlight; cracks due to drying and curing of concrete, stucco, plaster, bricks or masonry; drying, shrinking and cracking of caulking of ceramic tile and grout discoloration and grout falling out; nail-pops; deterioration of concrete due to scaling, spalling, cracking, drying and curing, pitting in the concrete and corrosive materials such as salt or oil or the use of heavy trucks; and settling of the Home or the ground under the Home or under and around other adjacent homes.
- (e) Grading, leveling or surface draining relating to the Home or the Unit.
- (f) Defects in or damages to any items or materials installed or replaced by Purchaser or any other person except Builder or the authorized agents and subcontractors of Builder acting at Builder's request. Work done by Purchaser or any other person except Builder or Builder's authorized agents and subcontractors acting at Builder's request (such work shall void this New Home Limited Warranty with respect to the portion of the Home affected by such work). Damages to additions (e.g., decks, etc. or landscaping) as a consequence of Builder making proper access to repair a warranty item. Additional warranty repair costs incurred by Builder as a consequence of items, materials or additions installed or replaced by Purchaser or any other person, other than Builder.
- (g) Loss or injury due to the elements.
- (h) Conditions resulting from condensation on, or expansion or contraction of, materials.
- (i) Scratches, chips or similar defects in plumbing products.
- (j) ANY CONSEQUENTIAL, INCIDENTAL, SPECIAL OR SECONDARY DAMAGES ARISING OUT OF ANY DEFECTS IN MATERIALS OR WORKMANSHIP OR ARISING OUT OF ANY CLAIM MADE UNDER THIS NEW HOME LIMITED WARRANTY. In no event will Builder be liable for such damages even if Builder has been advised of the possibility of such damages, nor shall Builder be liable for or responsible to compensate or indemnify Purchaser for any damage, claim, demand, loss, cost or expense resulting from an alleged claim of breach of warranty hereunder, whether relating to injury to persons, property, or otherwise, or relating to the presence of any toxic or hazardous waste, substance, or contaminant, including without limitation radon gas, in, on or under the Unit or the Home, the Condominium or the real estate adjacent to or close proximity with the Condominium.
- (k) Defects or other matters for which Builder, after reasonable efforts, has been unable to remedy as a result of being denied access by Purchaser to the Home.
- (l) Any damage to the extent it is caused by or made worse by:
 - (i) Negligence, improper maintenance or improper operation by anyone other than Builder, its employees, agents or subcontractors.

Purchaser's Initials:

_____ / _____

Builder's Initials:

River Park Village Building Co., L.L.C.

By: _____

Its: Member

5. CLAIMS PROCEDURE AFTER CLOSING. If a defect appears that Purchaser reasonably believes is covered by this New Home Limited Warranty, Purchaser must file a written Warranty Service Request with Builder at its address noted above. Builder has no responsibility or liability hereunder for any claim which is not received by Builder which is made prior to the expiration of the one-year period set forth in Section 1 above. If delay will cause extra damage, Purchaser shall be obligated to call Builder's office immediately. Other than emergencies, all communications relating to this New Home Limited Warranty must be in writing. Purchaser must sign an acknowledgment of the completion of each repair after the same is completed (in the event Purchaser is made up of two or more individuals, then, only one of such individuals must sign such acknowledgment). Failure to sign an acknowledgment upon request will terminate this New Home Limited Warranty and relieve Builder of any further obligation to make additional repairs.

6. REMEDY. Upon receipt of a claim of defect, Builder shall investigate the same. If upon such investigation it is determined that the defect claimed is covered by this New Home Limited Warranty, Builder shall correct such defect by repair or replacement at no charge to Purchaser within a reasonable period, not to exceed sixty (60) days, unless weather, material shortages or labor problems create delays. The decision as to repair or replacement in connection with the correction of the defect shall be made solely by Builder. All work performed hereunder shall be done by Builder or its authorized agents. REPAIR OR REPLACEMENT OF DEFECTIVE ITEMS IS PURCHASER'S SOLE AND EXCLUSIVE REMEDY UNDER THIS LIMITED WARRANTY.

7. TRANSFERABILITY. This New Home Limited Warranty is extended to Purchaser, is not assignable and is not available to any person or persons who may own the Home during the term of the warranty provided herein other than Purchaser. This Warranty shall terminate at such time as Purchaser shall sell or move out of the Home.

8. NO OTHER WARRANTIES. THIS NEW HOME LIMITED WARRANTY IS THE ONLY WARRANTY MADE BY BUILDER. ALL OTHER WARRANTIES, EXPRESS OR IMPLIED, WHETHER ARISING UNDER STATE LAW OR THE MAGNUSON-MOSS WARRANTY ACT INCLUDING BUT NOT LIMITED TO ALL IMPLIED WARRANTIES OF FITNESS, MERCHANTABILITY OR HABITABILITY, ARE DISCLAIMED AND EXCLUDED. EXCEPT AS EXPRESSLY SET FORTH IN THIS NEW HOME LIMITED WARRANTY, BUILDER HAS MADE NO REPRESENTATIONS OR WARRANTIES CONCERNING THE HOME, THE CONDOMINIUM, THE VALUE OR RESALE VALUE OF THE HOME, THE REAL ESTATE ADJACENT TO OR IN CLOSE PROXIMITY WITH THE CONDOMINIUM, OR THE CONDITION OF THE AIR, SOIL, SURFACE WATER, AND GROUND WATER IN, ON, OR UNDER THE UNIT OR THE HOME, THE CONDOMINIUM, OR ANY ADJACENT OR PROXIMATE REAL ESTATE. PURCHASER HAS MADE ITS OWN INVESTIGATION WITH RESPECT TO THE FOREGOING.

9. APPLICABLE LAW. This New Home Limited Warranty shall be construed in all respects and governed by the laws of the State of Michigan.

10. CLAIMS PROCEDURE. If a defect appears which Purchaser thinks is covered by this New Home Limited Warranty, Purchaser must notify Builder in writing at Builder's address appearing in Section 1 of this New Home Limited Warranty. Builder will not assume responsibility for responding to any notice delivered to Builder more than 14 days after the expiration of the one-year warranty period, even if the defects that are claimed in the letter may have arisen within the one-year warranty period. Purchaser must identify in any such notice to Builder specific times during the day Purchaser will be available at the Home so that Builder may schedule service calls appropriately. If a delay or delays will cause extra damage, Purchaser must immediately telephone Builder and advise Builder of the defects claimed. Only emergency reports will be taken by phone.

Purchaser's Initials:

_____ / _____

Builder's Initials:

River Park Village Building Co., L.L.C.

By: _____

Its: Member

EXHIBIT D

ACKNOWLEDGEMENT OF NO REPRESENTATIONS

By initialing below, Purchaser acknowledges that Builder and its representatives have not made any representations, warranties or promises with respect to the subject matter of the Agreement which are not set forth, in writing, in the Agreement.

Purchaser's Initials:

_____ / _____

Builder's Initials:

River Park Village Building Co., L.L.C.

By: _____

Its: Member

EXHIBIT E

FINANCING CONTINGENCY

The terms and provisions of this Financing Contingency shall be deemed to form a part of the terms and provisions of the Construction and Sales Agreement to which it is attached. In the event of a conflict between the terms and provisions of this Contingency and the terms and provisions of the Construction and Sales Agreement, the terms and provisions of this Contingency shall prevail. Capitalized terms used in the Construction and Sales Agreement shall have the same meanings when used in this Contingency.

1. Builder and Purchaser acknowledge that their respective obligations under the Construction and Sales Agreement are conditioned upon Purchaser obtaining a mortgage loan commitment ("Commitment") from an institutional mortgage lender ("Lender") committing such Lender to make a mortgage loan ("Loan") in the amount of \$ _____ to Purchaser secured by a mortgage upon the Property.

2. Purchaser shall be required, within three days after the execution of the Construction and Sales Agreement by Builder, to apply to a Lender for the Commitment and to cooperate diligently and in good faith with such Lender to cause such application to be duly processed. In the event that Purchaser has been rejected by the first Lender to which it applied for the Commitment, Purchaser shall within three days after such rejection, apply to a second Lender for the Commitment

3. Purchaser shall require each Lender to which it applies for the Loan to provide to Builder copies of either the rejection letter of any such Lender evidencing its rejection of Purchaser's application for the Loan or a copy of the Commitment evidencing its commitment to make the Loan. Purchaser shall require each Lender to provide such copies to Builder simultaneously with such Lender's delivery of the same to Purchaser.

4. In the event that Purchaser has not obtained the Commitment on or before the expiration of 30 days after the date of execution of the Construction and Sales Agreement by Builder, then, provided that Purchaser has delivered to Builder, on or before the end of such 30 day period, rejection letters from at least two lenders with respect to Purchaser's loan applications made with such Lenders, Purchaser shall have the right to terminate the Construction and Sales Agreement, upon written notice to Builder, if at all, on or before five days following the expiration of the 30 day period referred to above, in which event the Deposit shall be returned to Purchaser and neither party shall thereafter have any obligation under the Construction and Sales Agreement. In the event that Purchaser has not obtained and delivered the Commitment to Builder, as required above, and in the event that Purchaser has not exercised its right to terminate the Construction and Sales Agreement within the time frame and in accordance with the terms of the foregoing sentence, or in the event that Builder has received copies of rejections from two separate Lenders indicating their respective rejections of the Purchaser's application for the Loan, then, Builder shall have the right to terminate the Construction and Sales Agreement at any time, in which event, the Deposit shall be returned to Purchaser and neither party shall thereafter have any obligation under the Construction and Sales Agreement.

5. In the event the Construction and Sales Agreement has not been terminated in accordance with the foregoing or in the event Purchaser delivers to Builder a copy of the Commitment on or before the end of the 30 day period referred to above, then, Purchaser shall be deemed to have obtained the Commitment and the parties shall be required, subject to any other conditions precedent set forth elsewhere in the Construction and Sales Agreement, to perform their obligations under the Construction and Sales Agreement and in accordance with its terms (including, but not limited to, the performance by Builder of its obligations under Section 10 of the Construction and Sales Agreement).

Purchaser's Initials:

_____ / _____

Builder's Initials:

River Park Village Building Co., L.L.C.

By: _____

Its: Member

6. Purchaser's initialing of this Contingency shall be deemed evidence of its direction to the Lenders to provide Builder with copies of their respective appraisals prepared in connection with the processing of Purchaser's loan application with each Lender.

7. In connection with all loan applications made by Purchaser pursuant to the foregoing, Purchaser shall inform each Lender to which it applies that Builder has caused a mortgage survey of the Property to be prepared by a licensed surveyor. Builder shall provide a copy of such survey to Lender, provided that Lender shall be required to pay the cost thereof (such cost to be competitive with the preparation of mortgage surveys of similar properties in the vicinity of the Property).

8. Notices required to be given hereunder shall be made by certified mail, return receipt requested, to the addresses set forth in the Construction and Sales Agreement. Notices so mailed shall conclusively be deemed to have been received on the third day following deposit in the United States mail.

9. Notwithstanding anything herein contained to the contrary, to the extent Purchaser shall be seeking to satisfy this Financing Contingency through procurement of a commitment for a so-called "non-conforming loan," this Financing Contingency shall not be deemed satisfied until such time as Builder has approved in writing of the terms and conditions of such loan and the lender making such loan, such approval to be granted or denied in Builder's sole and absolute discretion.

Purchaser's Initials:

_____ / _____

Builder's Initials:

River Park Village Building Co., L.L.C.

By: _____

Its: Member

2. **Radon Gas.** Radon is a naturally-occurring, colorless and odorless radioactive gas formed by the breakdown of uranium and radium deposits in the soil. Radon can escape from the soil and enter buildings. Preliminary studies by the United States Environmental Protection Agency suggest that prolonged exposure to radon gas may result in adverse health consequences. The extent to which an area of a specific home may be exposed to radon gas depends upon a number of factors, including, but not limited to, natural geologic conditions, climate, temperature, prior land use, ground water, construction materials and techniques, ventilation and air conditioning systems and homeowner maintenance. Because of the multitude of factors involved, it is difficult to predict whether a specific home may be subject to high radon levels unless specific tests are conducted by experts in the area. Builder neither has nor claims any expertise in radon gas, and it does not provide advice to homeowners about the acceptable levels or possible health hazards of radon gas. The United States Environmental Protection Agency, as well as state and local regulatory authorities are best equipped to render advice regarding the risks which may exist in a particular area, the risks associated with radon exposure, the methods available to detect and measure radon levels and whether remedial measures may be advisable in particular circumstances to reduce the risk of radon exposure. The United States Environmental Protection Agency has published two guides which are available to interested persons: "A Citizen's Guide to Radon: What It Is and What to Do About It," and "Radon Reduction Methods: a Homeowner's Guide."

Purchaser's Initials:

_____ / _____

Builder's Initials:

River Park Village Building Co., L.L.C.

By: _____

Its: Member

weekly report on North American Forest Products Markets) during the Relevant Period. The index is currently _____. The percentage increase in the Index during the Relevant Period shall be multiplied by \$_____ and the product shall be the increase in the Total Purchase Price of the Home. In no event shall there be a decrease in the Total Purchase Price despite any decrease in the Index. If publication of the Index shall be discontinued, the parties shall mutually agree upon an increase for Lumber Costs during the Relevant Period and such percentage increase shall be applied as if it, in fact, were the Index hereinabove referred to. If the parties cannot agree upon such increase, then, and in that event, the Index will be selected by arbitration in accordance with the rules of commercial arbitration of the American Arbitration Association.

DET_C\1371955.1

Purchaser's Initials:

_____ / _____

Builder's Initials:

River Park Village Building Co., L.L.C.

By: _____

Its: Member

1
2
3
4
5
6
7
8
9
10
11
12
13
14
15
16
17
18
19
20
21
22
23
24
25
26
27
28
29
30
31
32
33
34
35
36
37
38
39
40
41
42
43
44
45
46
47
48
49
50
51
52
53
54
55
56
57
58
59
60
61
62
63
64
65
66
67
68
69
70
71
72
73
74
75
76
77
78
79
80
81
82
83
84
85
86
87
88
89
90
91
92
93
94
95
96
97
98
99
100